

Operating manual

## Lubricator

LUC+125, 24 V, time-controlled



**Sales department**
**WITTENSTEIN alpha GmbH**

Walter-Wittenstein-Straße 1  
D-97999 Igersheim  
Germany

**Customer Service department**

In the event of technical questions, contact the following address:

		✉	☎
Deutschland	WITTENSTEIN alpha GmbH	service@wittenstein-alpha.de	+49 7931 493-12900
Benelux	WITTENSTEIN BVBA	service@wittenstein.biz	+32 9 326 73 80
Brasil	WITTENSTEIN do Brasil	vendas@wittenstein.com.br	+55 15 3411 6454
中国	威腾斯坦（杭州）实业有限公司	service@wittenstein.cn	+86 571 8869 5856
Österreich	WITTENSTEIN GmbH	office@wittenstein.at	+43 2256 65632-0
Danmark	WITTENSTEIN AB	info@wittenstein.dk	+45 4027 4151
France	WITTENSTEIN sarl	info@wittenstein.fr	+33 134 17 90 95
Great Britain	WITTENSTEIN Ltd.	sales.uk@wittenstein.co.uk	+44 1782 286 427
Italia	WITTENSTEIN S.P.A.	info@wittenstein.it	+39 02 241357-1
日本	ヴィッテンシュタイン株式会社	sales@wittenstein.jp	+81-3-6680-2835
North America	WITTENSTEIN holding Corp.	technicalsupport@wittenstein-us.com	+1 630-540-5300
España	WITTENSTEIN S.L.U.	info@wittenstein.es	+34 93 479 1305
Sverige	WITTENSTEIN AB	info@wittenstein.se	+46 40-26 50 10
Schweiz	WITTENSTEIN AG Schweiz	sales@wittenstein.ch	+41 81 300 10 30
台湾	威腾斯坦有限公司	info@wittenstein.tw	+886 3 287 0191
Türkiye	WITTENSTEIN Güç Aktarma Sistemleri Tic. Ltd. Şti.	info@wittenstein.com.tr	+90 216 709 21 23

**Copyright**

© **WITTENSTEIN alpha GmbH 2022** reserves all rights for layout and corporate design.

© **DLS Schmiersysteme GmbH 2022** reserves all rights for content and texts.

This documentation is protected by copyright.

**WITTENSTEIN alpha GmbH** and **DLS Schmiersysteme GmbH** reserve all rights to photo-mechanical reproduction, copying, and the distribution by special processes (such as computers, file media, data networks), in whole or in part.

Subject to technical and content changes without notice.

## Table of contents

<b>1</b>	<b>About this manual</b>	<b>3</b>
1.1	Information symbols and cross references	3
1.2	Scope of delivery	3
<b>2</b>	<b>Safety</b>	<b>3</b>
2.1	EC/EU Directive	3
2.2	Personnel	3
2.3	Intended use	4
2.4	Reasonably foreseeable misuse	4
2.5	Guarantee and liability	4
2.6	General safety instructions	5
2.7	Structure of warning instructions	5
2.7.1	Safety symbols	5
2.7.2	Signal words	6
<b>3</b>	<b>Description of the lubricator</b>	<b>7</b>
3.1	Overview of lubricator components	7
3.2	Name plate and labeling	7
3.3	Marking	8
3.4	Ordering codes	8
3.5	Dimensions	8
3.6	Scope of delivery	8
3.7	Technical data	9
3.8	Lubricants	10
3.9	Line lengths	10
<b>4</b>	<b>Transport and storage</b>	<b>10</b>
4.1	Transport	10
4.2	Storage	10
<b>5</b>	<b>Assembly</b>	<b>11</b>
5.1	Preparations	11
5.2	Mounting the lubricator	11
5.3	Connecting the prefilled hose	11
5.4	Electrical interface connection	12
<b>6</b>	<b>Startup and operation</b>	<b>12</b>
6.1	Operation and settings	12
6.1.1	General	12
6.1.2	Factory settings	13
6.1.3	Actions with magnetic pen	14
6.2	Menu and display messages	14
6.3	Selection of parameters t and c	16
6.3.1	Menu structure	17
6.4	Error messages	18

6.5	Switching the lubricator on/off.....	19
6.6	Parameter change in standard menu (Pro).....	20
6.7	Triggering single lubrication processes.....	21
6.8	Triggering the filling function (venting/filling).....	21
6.9	Changing parameters in the "Advanced programming" menu.....	22
<b>7</b>	<b>Output signals – Time control .....</b>	<b>23</b>
7.1	Connection assignment – Time control.....	23
7.2	Factory setting E1 – L1 – F0.....	23
7.3	Standard output signals at PIN 4 – Time control .....	24
7.3.1	Empty cartridge signal .....	24
7.3.2	High-signal output (+24 V) at PIN 4.....	24
7.3.3	Low-signal output (+0 V) at PIN 4.....	24
7.3.4	Output signals / display messages – Time control when changing the factory settings .....	25
7.3.5	Output signal 0.5 Hz square-wave signal at PIN 4 .....	26
<b>8</b>	<b>Maintenance and disposal .....</b>	<b>27</b>
8.1	Maintenance schedule .....	27
8.1.1	Visual inspection.....	27
8.1.2	Cleaning .....	27
8.1.3	Cartridge change .....	28
8.2	Recommissioning .....	30
8.3	Disposal .....	30
<b>9</b>	<b>Appendix.....</b>	<b>31</b>
9.1	EC/EU declaration of conformity.....	31

## 1 About this manual

This manual contains information which is necessary for the safe use of the LUC+125 (FlexxPump 125), version 24 V-DC (time-controlled), hereinafter referred to as lubricator.

If this manual is supplied with amendment sheets (e.g. for special applications), then the information in the amendment is valid. Contradictory specifications in this manual are therefore void.

The user should contact **WITTENSTEIN alpha GmbH** with any questions about special applications. The actual and effective operator must guarantee and ensure that this manual including any amendments are read through by all persons assigned to install, operate, or maintain the lubricator, and that they fully comprehend them. For this reason, keep this manual in a suitable and ideally accessible location near the lubricator.

Inform colleagues who work in the area around the machine about the safety instructions so that no one sustains injuries.

The original was prepared in German, all other language versions are translations of the original manual.

### 1.1 Information symbols and cross references

The following information symbols are used:

- Indicates an action to be performed
- Ü Indicates the results of an action
- i Provides additional handling information

A cross reference refers to the chapter number and the header of the target section (e.g. 2.3 "Intended use").

A cross reference to a table refers to the table number (e.g. Table "Tbl - 1").

### 1.2 Scope of delivery

- Check the completeness of the delivery against the delivery note.
- i Immediately notify the carrier, the insurance company, or **WITTENSTEIN alpha GmbH** in writing of any missing parts or damage.

## 2 Safety

This manual, especially the safety instructions and the rules and regulations valid for the operating site, must be observed by all persons working with the lubricator. General legal rules and regulations as well as applicable rules and regulations on prevention of accidents [e.g. personal protective equipment (PPE)] and environmental protection must be observed.

### 2.1 EC/EU Directive

In scope of the EC/EU Directive, commissioning (recommissioning) of a machine at which the lubricator was installed and/or attached is prohibited until it is verified that the machine complies with all provisions of the applicable regulation.

An EC/EU declaration of conformity for this lubricator can be found in the appendix (see chapter 9.1 "EC/EU declaration of conformity").

### 2.2 Personnel

Only technicians who have read and understood this operating manual may perform work on the lubricator. Local and/or company regulations apply accordingly.

## 2.3 Intended use

For the intended use of the lubricator, the following points must be observed:

- The lubricator is approved only for industrial applications.
- The lubricator may only be put into operation according to the technical specifications (see chapter 3.7 "Technical data").
- Unauthorized modifications to the lubricator are not permitted.
- Read and observe the operating manual.
- During operation of the lubricator, regular visual inspections must be carried out at the lubricator itself as well as the lubrication point. Any irregularities and their cause must be corrected immediately.
- The cartridge must not be refilled.
- The lubricator must not be opened or dismantled.
- Only lubricants which are approved by **WITTENSTEIN alpha GmbH** may be used.
- Applicable rules and regulations on occupational safety, prevention of accidents and environmental protection must be observed.
- Any works or activities with or at the lubricator may only be carried out with authorization (see chapter 2.2 "Personnel").

Any use other than the previously described intended use or non-compliance with one of the points specified above is regarded misuse. In this case no liability or warranty claims will be assumed.

## 2.4 Reasonably foreseeable misuse

Any usage of the lubricant that exceeds the maximum permitted technical data is considered misuse and is therefore prohibited.

## 2.5 Guarantee and liability

Any guarantee and liability claims are excluded for personal injury and/or material damage in case of:

- Ignoring the information on transport and storage;
- Misuse;
- Improper or not carried out maintenance and repair;
- Incorrect assembly / disassembly or incorrect operation;
- Operation of the lubricator when safety devices and equipment are defective;
- Operation of the lubricator without lubricant;
- Operation of the lubricator with non-approved lubricant;
- Operation of a heavily contaminated lubricator;
- Modifications or changes without written approval by **WITTENSTEIN alpha GmbH**;
- Opening and/or partly or complete dismantling of the lubricator.

## 2.6 General safety instructions

The operation of the lubricator involves residual risks even when adhering to the intended use.

**Defective or faulty electrical connections or unapproved, current-carrying components** can cause serious injuries and even death.

- Have all electrical connection work performed by qualified technicians only.
- Immediately replace damaged cables or plugs.

**Loose or overloaded screw connections** can cause damage to the lubricator:

- Mount and check all screw connections according to the specified admissible tightening torques. Use a calibrated torque wrench.

**Lubricants** are flammable, can cause skin irritation, and can pollute soil and water:

- In case of fire, do not use a jet of water to extinguish.
- In case of fire, only use suitable extinguishing agents such as powder, foam or carbon dioxide.
- Always observe the applicable safety instructions by the lubricant manufacturer on the safety data sheet of the used lubricant.
- Use protective gloves to avoid direct skin contact with lubricants.
- Use and dispose of lubricants properly.

## 2.7 Structure of warning instructions

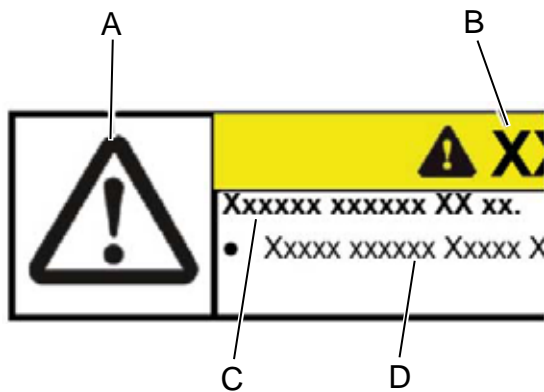

Warning instructions are situation-specific. They will be given precisely where tasks are described in which dangers can arise.

The warning instructions in this manual are designed according to the following pattern:

**A** = safety symbol

**B** = signal word

**C** = type and consequence of the danger

**D** = avoidance of the danger

### 2.7.1 Safety symbols

The following safety symbols are used to indicate hazards, prohibitions and important information:



General danger



Electric voltage



Flammable



Environment

2.7.2 Signal words

	<p style="text-align: center;"><b>⚠ DANGER</b></p> <p>This signal word indicates an imminent danger that will cause serious injuries or even death.</p>
	<p style="text-align: center;"><b>⚠ WARNING</b></p> <p>This signal word indicates a potential hazard that could cause serious injuries and even death.</p>
	<p style="text-align: center;"><b>⚠ CAUTION</b></p> <p>This signal word indicates a potential hazard that could cause minor or serious injuries.</p>
	<p style="text-align: center;"><b>NOTICE</b></p> <p>This signal word indicates a potential hazard that could lead to property damage.</p>



### 3 Description of the lubricator

The lubricator is designed as a highly compact double piston pump for grease as lubricant. The two pistons run with forced-control and in opposed directions. They are both connected to the same outlet. The outlet is secured by an integrated check valve. At each dispensing process, approx. 0.15 cm<sup>3</sup> of lubricant are dispensed. Multiple subsequent dispensing processes can be set.

The lubricator features an electrical interface. The included magnetic pen allows for the lubrication volume dispensed per time to be adjusted or set to ensure ideal supply of lubricant to the lubrication point.

The different operating modes are displayed at the front as well as other additional information (e.g. empty cartridge, errors).

Power supply is established via interface M12x1. This interface can also be used to relay information on an empty cartridge as well as error messages, e.g. to an external control system.

#### 3.1 Overview of lubricator components

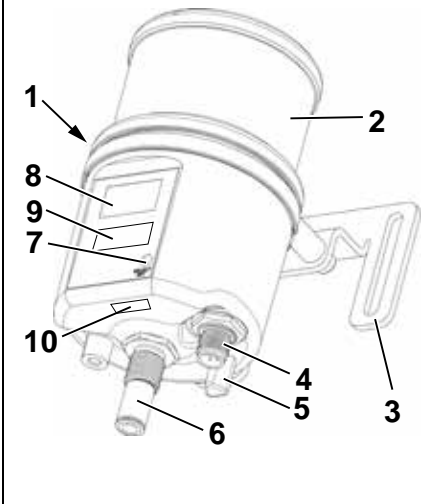
	Pos.	Designation
	1	LUC+125, 24 V, time-controlled
	2	Exchange cartridge LUE+125
	3	Assembly bracket
	4	Interface M12x1, 4-pole
	5	Magnetic pen (in holder)
	6	Hose connection
	7	Action field
	8	Display
	9	Name plate
	10	CE mark

Tbl - 1 Overview of lubricator components

#### 3.2 Name plate and labeling

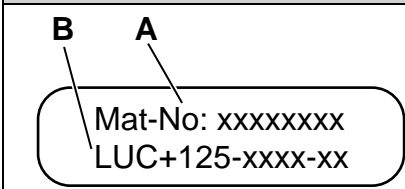
	Pos.	Designation
	A	Material number
	B	Ordering codes (see chapter 3.4 "Ordering codes")

Tbl - 2 Name plate

### 3.3 Marking

The CE mark is attached to the lubricator housing. The position of the CE mark is described in chapter 3.1 "Overview of lubricator components".

#### Manufacturer

DLS Schmiersysteme GmbH  
 Gewerbering 5  
 82140 Olching, Germany  
 Tel.: +49-(0)8142-65069-0  
 Fax: +49-(0)8142-65069-29  
 Email: mail@DLS-Schmiersysteme.de  
 www.DLS-Schmiersysteme.de

### 3.4 Ordering codes

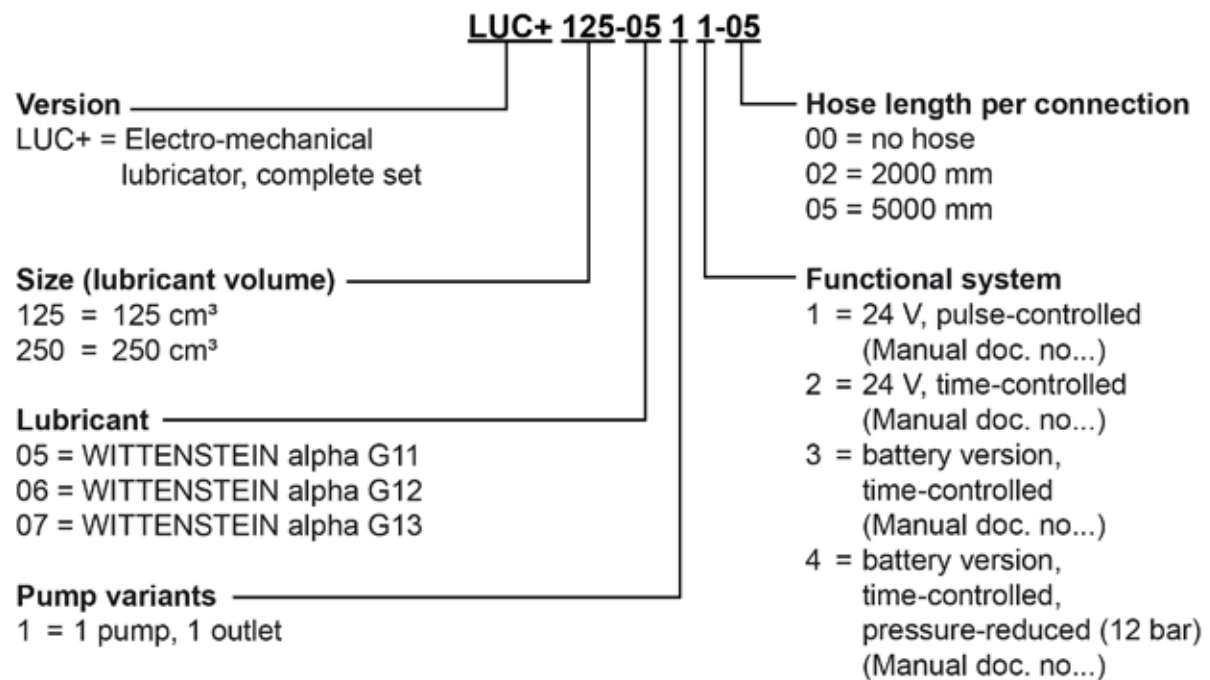

### 3.5 Dimensions

Dimensions can be found

- in our catalog,
- under [www.wittenstein-alpha.de](http://www.wittenstein-alpha.de).

CAD data and dimension sheets are available upon request.

### 3.6 Scope of delivery

The lubricator is available in different versions. They can be distinguished by general features, the lubricant filling as well as the included accessories.

### 3.7 Technical data

Housing		
Dimensions without cartridge	83 x 96 x 85 (W x H x D)	mm
Dimensions with cartridge 125 cm <sup>3</sup>	83 x 154 x 85 (W x H x D)	mm
Dimensions with cartridge 250 cm <sup>3</sup>	83 x 188 x 85 (W x H x D)	mm
Weight (without cartridge)	approx. 350	g
Assembly option	Assembly bracket with slotted holes pre-assembled. Bottom side: IG M5 (3 Nm)	
Mounting position	vertically	
Housing material	PA 6.6 GF30 / POM	
Outlet material	Stainless steel	
Operating temperature *	0 ... +60	°C
Lubricant and hydraulics		
Cartridge volume	125 / 250	cm <sup>3</sup>
Lubricant properties	Grease up to NLGI, class 2	
No. of outlets	1	
Hydraulic connection	PA hose	
Number of lubrication points	Up to 4 in connection with splitter**	
Max. pressure	50 (-10%/+15%)	bar
Dispensed volume	Per stroke 0.15 (-5%)	cm <sup>3</sup>
Electrics		
Display	Display	
Operating voltage (DC)	24 (20V...28V)	V
Fuse	0.75 (slow)	A
Protection class	IP 54	
Power consumption	$I_{\max} < 0.3$ $I_{\text{bias}} < 0.025$	A
For further information on the electrical system, see chapter 7 "Output signals – Time control"!		
* Depending on the lubricant used		
* The specified value depends on the actual application and may deviate in individual cases depending on the used lubricant and other conditions.		

Tbl - 3 Technical data

### 3.8 Lubricants

Only use lubricants approved by **WITTENSTEIN alpha GmbH** in dedicated original cartridges exclusively developed for the lubricator.

	<p><b>The lubricants used depend on the individual application. The respective designation can be found on the label of the cartridge.</b></p>
--	------------------------------------------------------------------------------------------------------------------------------------------------

For further information about lubricants, documentation and safety data sheets, please contact **WITTENSTEIN alpha GmbH** directly.

### 3.9 Line lengths

In general, the lubricator should be installed as closely as possible to the device to be supplied (lubrication point). Ideally, this should be directly at the lubrication point. If this is not possible due to space restrictions or reasons regarding accessibility, lines can be used between the lubricator and the lubrication point (e.g. distribution).

The maximum hose length depends on the temperature as well as the used grease, hoses and accessories.

## 4 Transport and storage

The lubricator is delivered in an outer packaging (cardboard box) and with a lubricant cartridge and other accessories in the same bundle. For protection against humidity and dirt, these are additionally packaged in PE foil. To prevent leakage of the prefilled lubricant from the lubricator, protective caps are installed at the lubricant inlet and outlet.

Dispose of the packaging materials at the recycling sites intended for this purpose in compliance with applicable national and operational regulations.

After receipt of the lubricator, check the completeness of the delivery against the delivery note.

Immediately notify the carrier, the insurance company, or **WITTENSTEIN alpha GmbH** in writing of any potentially missing parts or damage.

### 4.1 Transport

	NOTICE
	<p><b>Hard shocks, for instance because of falling or hard dropping, can damage the lubricator.</b></p> <ul style="list-style-type: none"> <li>· Do not throw the lubricator.</li> </ul>

### 4.2 Storage

Store the lubricator in its original packaging in vertical position under dry, frost-protected conditions at an ambient temperature of +5°C to +30°C. The maximum unopened storage time is 2 years.

For storage logistics, the "First-In-First-Out principle" (FiFo) is recommended.

## 5 Assembly

The lubricator is delivered with an inserted lubricant cartridge in vented condition as a ready-to-install component with installed assembly bracket. The outlet is closed with a yellow cap.

The provided hose lines have already been prefilled with the respective lubricant.

### 5.1 Preparations

	NOTICE
	<p><b>Among other things, compressed air can lead to damage to the seals of the lubricator and to contamination of the lubricator or lubricant by dirt and particles.</b></p> <ul style="list-style-type: none"> <li>· Do not use compressed air.</li> <li>· Make sure that the assembly location is not considerably contaminated.</li> </ul>

### 5.2 Mounting the lubricator

	<ul style="list-style-type: none"> <li>· Observe the safety and processing instructions for the threadlocker to be used.</li> </ul>
--	-------------------------------------------------------------------------------------------------------------------------------------

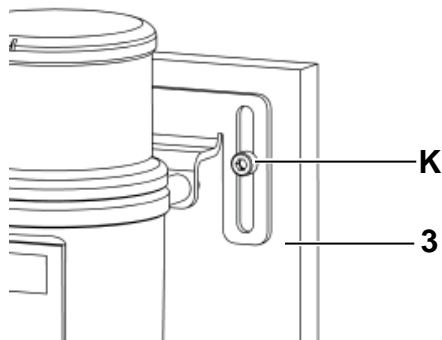

- Apply threadlocker (e.g. LOCTITE® 243) to the fastening screws [K].
- Install the lubricator with the pre-assembled assembly brackets [3] at the intended position. The slotted holes enable fine adjustment of the installation height.
- i The prescribed screw sizes and tightening torques can be found in the table "Tbl - 3".

Hole spacing [mm]	Quantity x diameter [ ] x [mm]	For screw size / property class	Tightening torque [Nm]
95	2 x 6.6	M6 / 8.8	9.0

Tbl - 4 Through-holes in assembly bracket

### 5.3 Connecting the prefilled hose

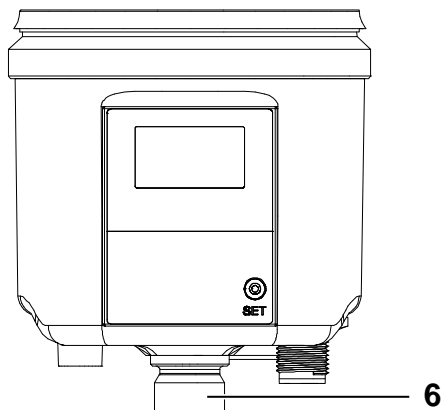

- Remove the yellow closing cap.
- Screw in the provided hose connection [6].
  - i Max. tightening torque 2 Nm.
- Establish the hydraulic connection between the equipment and the lubricator [6]. Ensure that hoses and connection elements are tight and properly assembled.
- i If possible, use the hoses prefilled with the respective lubricant included in the scope of delivery!

- i Further important instructions on how to connect the hose can be found in the separate manual "Prefilled high pressure hose" (doc. no. 2098-D072334). The manual is included in the scope of delivery of the hose or is available on request from **WITTENSTEIN alpha GmbH**. Always state the material number when doing so.

## 5.4 Electrical interface connection

	<b>⚠ DANGER</b>
<p><b>Defective or faulty electrical connections or unapproved, current-carrying components can cause serious injuries and even death.</b></p> <ul style="list-style-type: none"> <li>· Have all electrical connection work performed by qualified technicians only.</li> <li>· Immediately replace damaged cables or plugs.</li> <li>· Observe the five safety rules of electrical engineering before starting electrical installation work:           <ul style="list-style-type: none"> <li>- Switch off the power supply.</li> <li>- Secure against unintended reactivation.</li> <li>- Check that there is no voltage.</li> <li>- Ground and short-circuit.</li> <li>- Cover adjacent and electrified parts.</li> </ul> </li> </ul>	

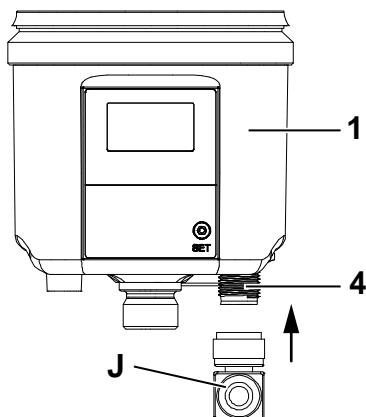

- Connect the lubricator [1] to the external power supply or control system with a suitable connection cable [J] via the M12x1 interface [4] at the bottom of the lubricator.
- i Depending on the application, connection cables with straight or angled socket can be used.
- i **For the properties of the connection cable, please refer to chapter 7.1 "Connection assignment – Time control".**

## 6 Startup and operation

- Read the general safety instructions before beginning to work (see chapter 2.6 "General safety instructions").
- Make sure that the lubricator is properly and fully assembled. In particular, the power supply must be connected, and a lubricant cartridge must be attached.

### 6.1 Operation and settings

#### 6.1.1 General

What you should know about operation and setting of the lubricator:

- The lubricator is designed as an individual lubricator for one lubrication point. However, the lubricator can also be used for reliable grease supply to several lubrication points depending on the actual application case. This can be achieved by connecting parts of the system accessories (e.g. splitters) to the lubricator. In such a case, it may be necessary to change the settings at the lubricator to ensure safe and reliable operation.

- The lubricator is time-controlled and works time-based via the integrated microelectronics and must be connected to a 24 V DC power supply. The lubricator cyclically delivers a defined volume of lubricant from the cartridge to the outlet.
- The relubrication volume is defined in months by the emptying time setting of the cartridge. Emptying times  $t$  of 1...36 month(s) and a number of cycles  $c$  of 1...10 can be set.
- The single-use changeable cartridges with a lubricant capacity of 125/250 cm<sup>3</sup> ensure controlled and consistent quality of lubricants and are filled without any trapped air. The lubricator offers a reliable supply to lubrication points and prevents downtime of machinery. This version of the lubricator is designed for grease lubricants.
- The lubricator **cannot** be used without an external 24 V DC power supply. The lubricant cartridge is included in the scope of delivery and already installed in the lubricator.
- The respective modes of the lubricator are shown on the display, which also enables recognition of the status by LEDs in different colors.
- The use of cartridges of a different size requires consultation with **WITTENSTEIN alpha GmbH**.
- In case of any questions regarding your applications and the correct settings for the lubricator, please contact **WITTENSTEIN alpha GmbH**.

### 6.1.2 Factory settings

Parameter Program menu	Designation	Factory settings	Result
<b>t</b>	Emptying time	6	6 months
<b>c</b>	Number of cycles	2	2 pump strokes per lubrication (0.15 cm <sup>3</sup> /stroke)

Tbl - 5 Factory settings program menu

Parameter	Designation	Factory settings	Result
<b>P</b>	Maximum pressure	50	50 bar
<b>Pu</b>	Control mode	0	Time control active
<b>U</b>	Cartridge size	12	Cartridge 125 cm <sup>3</sup>
<b>E</b>	Inverted output signals	1	Permanent high signal in case of error
<b>L</b>	Empty cartridge signal	1	Permanent high signal in case of error
<b>F</b>	Feedback signal	0	Low signal when motor is running

**Parameters  $P$ ,  $Pu$ ,  $U$ ,  $E$ ,  $L$  and  $F$  may only be changed after consultation.  
If you have any questions, please contact WITTENSTEIN alpha GmbH Sales / Customer Service.**

Tbl - 6 Advanced programming factory settings

### 6.1.3 Actions with magnetic pen

The magnetic pen attached to the bottom of the lubricator allows to perform actions and changes of settings on the lubricator. This magnetic pen can be easily and safely stored permanently under the lubricator.

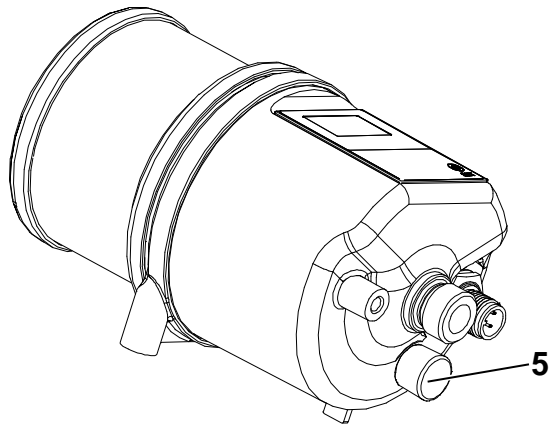

- Remove the magnetic pen [5] from the bottom of the lubricator.
- i The magnetic pen is permanently held magnetically in the receptacle on the bottom. Simply pull it out.

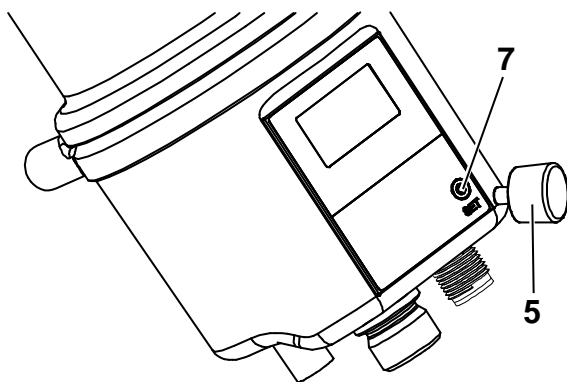

- Guide the magnetic pen [5] onto the action field *SET* [7] at the front of the lubricator.
  - ⊘ As soon as the magnetic pen is recognized by the lubricator as being on the action field *SET*, the red LED lights up in the display. The menu scrolls at a rate of 2 seconds.
  - Remove the magnetic pen from the action field *SET* when the desired menu item is shown on the display.
  - ⊘ The red LED is turned off. You have performed an action. The display flashes 2x briefly together with the green LED.
- After having performed the desired action or settings, insert the magnetic pen back into the receptacle provided on the bottom of the lubricator.

### 6.2 Menu and display messages

The display of the lubricator is used to show various kinds of information to the user.

Symbol	Designation	Notice
	Display information	The display visually shows information both during operation and for programming.

Tbl - 7 Display information

Display	Assignment
	Top LED: red
	Bottom LED: green

Tbl - 8 LED assignment



Information in display	Meaning		See chapter
<b>No display</b>	Power supply not connected		6.1
<b>OFF</b>	Lubricator switched off		6.5
<b>ON</b>	Lubricator ready for operation		6.5
<b>PRO</b>	<b>PRO menu</b>		6.6
	c1 ... 10	Adjustable setting of the number of cycles <i>c</i>	
	01 ... 35	Adjustable setting of the emptying time <i>c</i>	
<b>RUN</b>	<b>RUN menu</b>		6.7
	01 ... 50	During the manually triggered active <i>run</i> command, the display shows the approximate counterpressure in bar. In addition, the green LED lights up.	
<b>FIL</b>	<b>FIL menu</b>		6.8
	01...50	During the manually triggered active <i>FIL</i> command, the display shows the approximate counterpressure in bar. In addition, the green LED lights up.	
	Clr	If the process is canceled during the <i>FIL</i> command, <i>Clr</i> is displayed.	
<b>INF</b>	<b>INF menu</b>		6.9
	y01	Firmware version of the lubricator	
	r01	Firmware version of the lubricator	
	Pu0	Set control mode	
	t06	Currently set value of the emptying time <i>t</i>	
	c02	Currently set value of the number of cycles <i>c</i>	
	P50	Currently set maximum pressure <i>P</i>	
	U12	Currently set value of the cartridge size	
	E1	Currently set error output	
	L1	Currently set empty cartridge message	
	F0	Currently set feedback signal	
<b>E1</b>	Error <i>E1</i> (empty cartridge)	6.4	
<b>E2</b>	Error <i>E2</i> (cartridge error / no cartridge fitted)	6.4	
<b>E3</b>	Error <i>E3</i> (undervoltage)	6.4	
<b>E4/E5</b>	Error <i>E4/E5</i> (fatal error)	6.4	
<b>E7</b>	Error <i>E7</i> (overload)	6.4	
<b>01 ... 50</b>	After each cycle, the maximum applied counterpressure during the cycle is displayed in bar.		

Tbl - 9 Display messages

**6.3 Selection of parameters  $t$  and  $c$** 

	NOTICE
	<p>The emptying time <math>t</math> can be set on the lubricator only if it is not prescribed as a command by an external control system (parameter value <math>Pu0</math>).</p>

Emptying time $t$		Month									
	Cartridge size	1	3	6	10	12	15	20	24	30	36
<b>Lubrication volume per month [cm<sup>3</sup>]</b>	125 (U12)	125	41.6	20.8	12.5	10.4	8.3	6.3	5.2	4.2	3.5
	250 (U25)	250	83.3	41.6	25	20.8	16.7	12.5	10.4	8.3	6.9

 Tbl - 10 Emptying time  $t$  for cartridge

Values for  $t$  are exemplary, values from 1 - 36 (24 V version) can be set.

Number of cycles $c$	1	2	3	4	5	6	7	8	9	10
<b>Lubrication volume per cycle [cm<sup>3</sup>]</b>	0.15	0.3	0.45	0.6	0.75	0.9	1.05	1.20	1.35	1.5

 Tbl - 11 Number of cycles  $c$ , strokes per cycle

The emptying time  $t$  sets the period over which the total volume of lubricant per cartridge is delivered. Accordingly, this also determines how much lubricant is supplied per month.

The number of cycles  $c$  indicates how many strokes are performed per lubrication process and how much lubricant is supplied per lubrication process (1 stroke = 0.15 cm<sup>3</sup>).

The time between two lubrication processes (pause time) can be determined with the following formula:

$$T_{\text{Pause}} = t \times 720 \text{ h} \times c / H$$

Using  $t$  in hours and  $H$  as the number of total strokes per cartridge (830, for cartridge 125 cm<sup>3</sup>) and a lubrication volume of 0.60 cm<sup>3</sup> ( $c4$ ) over 6 months, the following pause time is obtained as an example:





$$T_{\text{Pause}} = 6 \times 720 \text{ h} \times 4 / 830 = 20.9 \text{ h}$$

For above parameters  $t$  and  $c$ , the lubrication cycle is 21 hours. A lubrication volume of 0.60 cm<sup>3</sup> is dispensed every 21 hours over a period of six months.

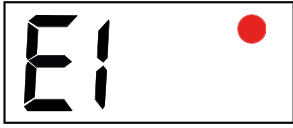

## 6.4 Error messages

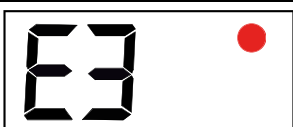
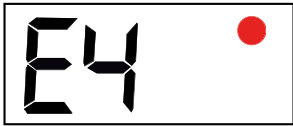
The status is permanently monitored by the microelectronics integrated in the lubricator. In case of any irregularities, an addressed error message is issued and shown on the display. The red LED flashes every 5 seconds to visually indicate an error.

Display	Error	Explanation	Correction
	E1	Cartridge empty	<ul style="list-style-type: none"> <li>· Place a new cartridge on the lubricator (see chapter 8.1.3 "Cartridge change").</li> <li>i No need to acknowledge the error; it is automatically cleared after the corrective action is performed.</li> </ul>
	E2	Cartridge error; cartridge not recognized or incorrectly fitted	
	E3	Undervoltage	<ul style="list-style-type: none"> <li>· Check the power supply of the lubricator</li> <li>· Switch the lubricator off (<i>OFF</i>) and on again (<i>On</i>).</li> </ul>
 	E4/E5	Fatal error	<p>The error <i>E4/E5</i> can have different causes:</p> <ul style="list-style-type: none"> <li>- Increased voltage for a short time, 28...30 V, and too short motor runtime.</li> <li>- The connected supply voltage was too low and therefore the motor runtime too long.</li> </ul> <p>· In these cases, the error is corrected by switching the lubricator off and on again.</p> <p><b>Important!</b> Between switching the lubricator off and on, 60 seconds must be waited.</p> <p>· If the error <i>E4 / E5</i> still persists, remove the lubricator from the application and return it with the lubricant cartridge and a description of the error to <b>WITTENSTEIN alpha GmbH</b> for inspection.</p>
	E7	Overload; the counterpressure at the lubrication point is too high	<ul style="list-style-type: none"> <li>· Check the lubrication point and eliminate the cause.</li> <li>· Switch the lubricator off (<i>OFF</i>) and on again (<i>On</i>).</li> </ul>

Tbl - 13 Malfunctions

- i If the lubricator is connected to an external control system (PLC), for example, when an error occurs, the differentiated error messages are sent to the PLC for errors *E1 ... E7* as output signals via PIN 4 of the electrical interface of the lubricator (see chapter 7.2 "Factory setting E1 – L1 – F0").

## 6.5 Switching the lubricator on/off

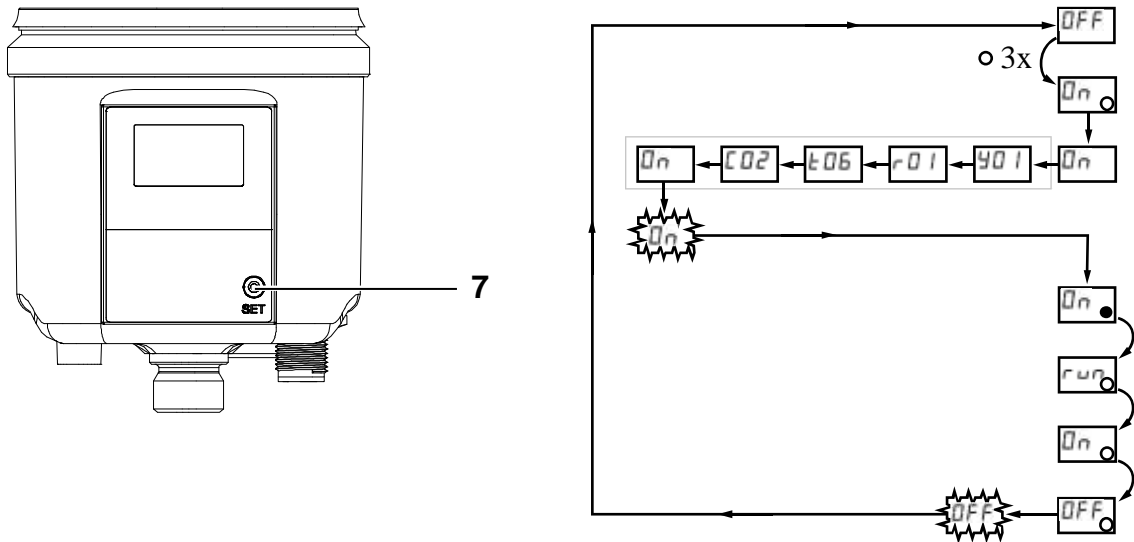

### Switching on

- Hold the magnetic pen against the action field [7].
  - Ü The LED flashes red three times.
  - Immediately remove the magnet pen when *On* is displayed.
  - Ü The firmware information and settings for emptying time *t* and number of cycles *c* are displayed.
  - Ü The word *On* flashes on the display twice.
  - Ü The green LED flashes, the lubricator is in operation.
- Lubricant dosing is carried out by the lubricator according to the presettings for *t* and *c*.

### Switching off

- Hold the magnetic pen against the action field [7].
- Ü The LED flashes red and the display shows *run*, *On*, *OFF* in sequence.
- Immediately remove the magnet pen when *OFF* is displayed.
- Ü The word *OFF* flashes on the display twice.
- Ü The lubricator is switched off.

## 6.6 Parameter change in standard menu (Pro)

### Settings for emptying time and number of cycles

The following parameters can be set in the standard menu:

- Control mode  $Pu$
  - Emptying time  $t$
  - Number of cycles  $c$
- i A description of the individual parameters can be found in chapter 6.1.2 "Factory settings".

	NOTICE
	<p><b>Changing the parameter value <math>Pu0</math> switches the lubricator from time mode to pulse mode. For this reason, the value may only be changed after consultation!</b></p>

### Changing parameters

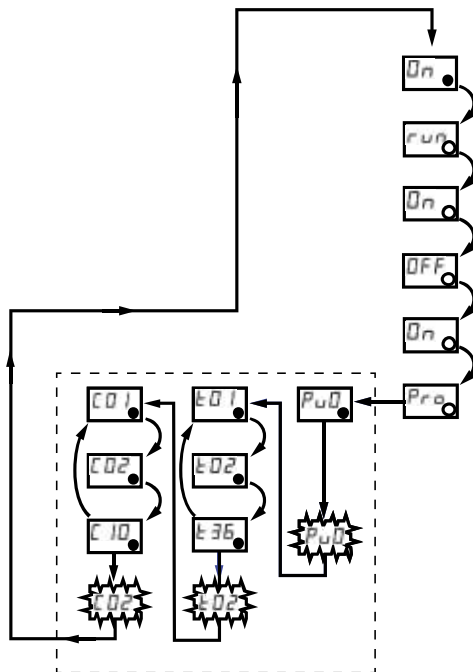

- Ü Lubricator in operation (*On*).
- Hold the magnetic pen against the action field.
- Ü The LED flashes red and the display shows *run*, *On*, *OFF*, *On*, *Pro* in sequence.
- Remove the magnetic pen when *Pro* is displayed.
- Ü The display shows (depending on the lubricator type) the parameter value  $Pu0$  and the parameters  $t$  and  $c$  one after the other.
- Hold the magnetic pen against the action field when you see the parameter to be set.
- Ü In the display, the value for the parameter is counted up and starts again from the beginning after the highest value.
- When the desired value is reached, remove the magnetic pen from the action field.
- Ü The set value flashes twice. The display shows the next parameter.
- Ü After the last parameter, the lubricator automatically returns to operation.

### 6.7 Triggering single lubrication processes

The lubricator can be used to trigger a single lubrication process at any time during operation.

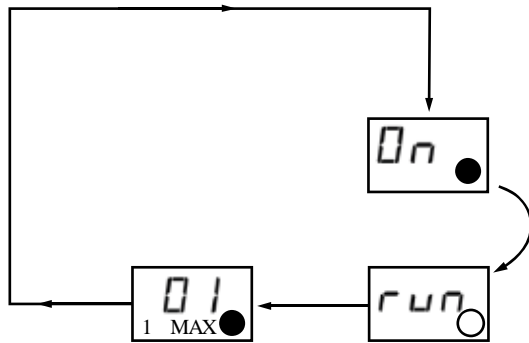

- Ü Lubricator in operation (*On*)
- Hold the magnetic pen against the action field.
- Ü The LED flashes red.
- Remove the magnetic pen when *run* is displayed.
- Ü The lubricator performs a single lubrication process.
- Ü The display shows the approximate counterpressure and the delivering pump piston.
- Ü After the lubrication process is finished, the lubricator automatically returns to operation.

### 6.8 Triggering the filling function (venting/filling)

The lubricator is delivered with a screwed-on cartridge, vented and with a pre-assembled mounting bracket.

For venting or filling of the lubrication point, the filling function of the lubricator can be triggered. The lubricator then automatically performs 40 delivery operations with a total lubrication volume of 6 cm<sup>3</sup>. The filling function can be canceled manually.

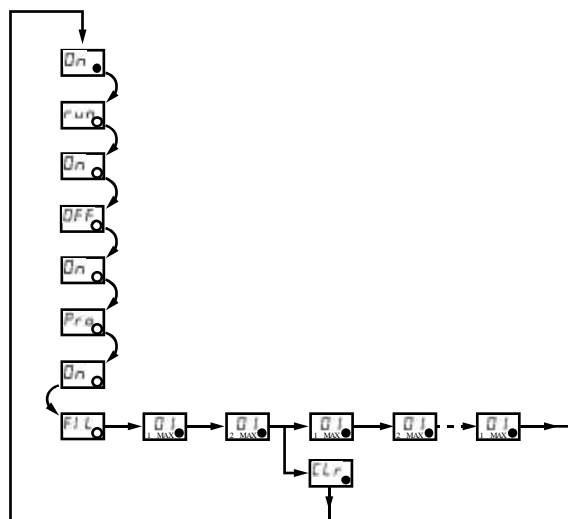

- Ü Lubricator in operation (*On*)
- Hold the magnetic pen against the action field.
- Ü The LED flashes red and the display shows *run*, *On*, *OFF*, *On*, *Pro*, *On*, *FIL* in sequence.
- Remove the magnetic pen when *FIL* is displayed.
- Ü The lubricator starts the filling process. The display shows the approximate counterpressure and the delivering pump piston.
- Ü After the lubrication process is finished, the lubricator automatically returns to operation.

#### Canceling the filling process

- During the filling function, hold the magnetic pen against the action field.
- Ü The display shows *Clr*.
- Remove the magnetic pen.
- Ü The filling function is canceled. The lubricator automatically goes into operation.

## 6.9 Changing parameters in the "Advanced programming" menu

	NOTICE
	<p><b>Changes in the menu can fundamentally affect the operation of the lubricator.</b></p> <ul style="list-style-type: none"> <li>Only change any advanced programming parameters if you are aware of the effects.</li> </ul>

The following parameters can be set in the "Advanced programming" menu:

- Control mode *Pu*
  - Emptying time *t*
  - Number of cycles *c*
  - Pressure *P*
  - Cartridge size *U*
  - Inversion of output signals *E*
  - Empty cartridge signal *L*
  - Feedback / motor run control *F*
- i A description of the individual parameters can be found in chapter 6.1.2 "Factory settings".

	NOTICE
	<p><b>The emptying time <i>t</i> of the lubricator can only be set in control mode (parameter value <i>Pu0</i>).</b></p>

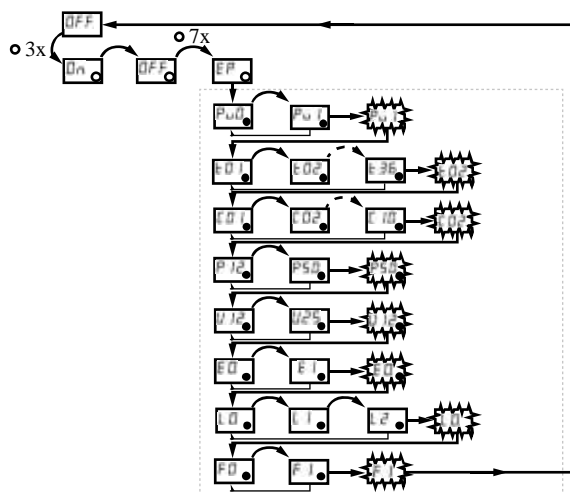

- ⊘ Lubricator switched off (*OFF*)
- Hold the magnetic pen against the action field.
- ⊘ The LED flashes red three times, then the display shows *On* followed by *OFF*. The LED flashes red seven times and the display shows *EP*.
- Remove the magnetic pen when *EP* is displayed.
- ⊘ The display shows the first parameter that can be changed.
- Hold the magnetic pen against the action field to change the parameter.
- ⊘ In the display, the value for the parameter is counted up and starts again from the beginning after the highest value.
- When the desired value is reached, remove the magnetic pen from the action field.
- ⊘ The set value flashes twice. The display shows the next parameter. If the parameter is not changed, the current value flashes twice.
- ⊘ After the last parameter, the lubricator is automatically switched off (*OFF*).



## 7 Output signals – Time control

The lubricator operates in time control mode as a time-based and cycle-controlled lubrication system according to the values set in the *PRO* menu.

### 7.1 Connection assignment – Time control

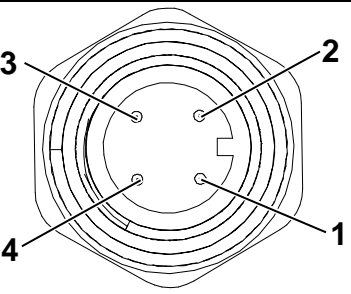
	PIN	Assignment	Color
	1	+24 V DC	Brown
	2	Not assigned	White
	3	Ground (GND)	Blue
	4	Output signal	Black
Type: M12x1 plug socket; 4-pin, A-coded			

Tbl - 14 PIN assignment – Time control

The lubricator can be fully shut down in time-control mode by switching off the supply voltage. The settings made are not lost. The time, starting at switch off until the next scheduled lubrication cycle is automatically saved by the lubricator in the integrated microelectronics. After the power supply is reconnected, the lubricator carries out an automatic self-check and continues to operate according to the set values.

- i After a longer standstill of the lubricator, manual triggering of a lubrication pulse is recommended (see chapter 6.7 "Triggering single lubrication processes").
- i The output signal at PIN 4 can be picked up for further processing (e.g. indicator light or external control system). The maximum admissible output current of  $I_{max} < 20$  mA must not be exceeded. No inductive load (e.g. relay) may be connected!

### 7.2 Factory setting E1 – L1 – F0

Display	Designation	Output signal (PIN 4)	See chapter
OFF	Switched off	Low, permanent	6.1
On	Ready	Low, permanent	7
01...50	Dispensing	Low, permanent	7
E1	Empty cartridge	High, permanent	7.3.2
E2	Cartridge error	High, permanent	7.3.3
E3	Undervoltage	High, permanent	7.3.2
E4/E5	Fatal error	High, permanent	7.3.2
E7	Overload/overpressure	High, permanent	7.3.2

Tbl - 15 Display messages at factory settings

### 7.3 Standard output signals at PIN 4 – Time control

In the time control mode (factory settings), the lubricator provides the output signals via the electrical interface. If necessary, the operating modes of the lubricator can be processed externally. The output signals can generally only be read and must not be subject to inductive or low resistive loads. This also enables remote status control, in addition to the visual indication at the display and LED on the lubricator.

#### 7.3.1 Empty cartridge signal

The integrated microelectronics of the lubricator are equipped with an automatic counter of the number of delivery operations after fitting a new and full cartridge. For a cartridge with 125 cm<sup>3</sup> of lubricant, the number of strokes is 780; for a cartridge with 250 cm<sup>3</sup> of lubricant, the number of strokes is 1560. The low difference in calculation serves as protection against the ingress of air into the hydraulic system. This ensures that the empty cartridge message (error *E1*) is sent in time [e.g. to the external control system (PLC)]. For this, a dedicated and unique output signal can be easily, quickly and reliably recognized by the external control system.

#### 7.3.2 High-signal output (+24 V) at PIN 4

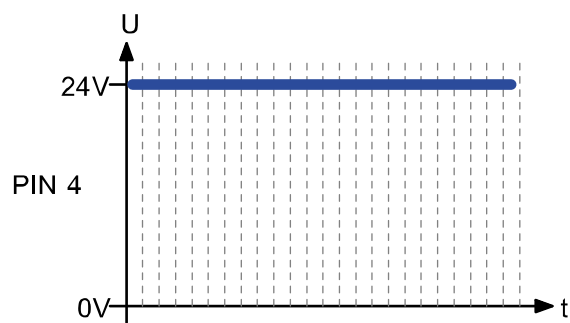

A permanent and continuous high signal (+24 V) at PIN 4 indicates that there is an active error. The error must be read on the display of the lubricator (see chapter 6.4 "Error messages"). The lubricator does not deliver any lubricant!

#### 7.3.3 Low-signal output (+0 V) at PIN 4

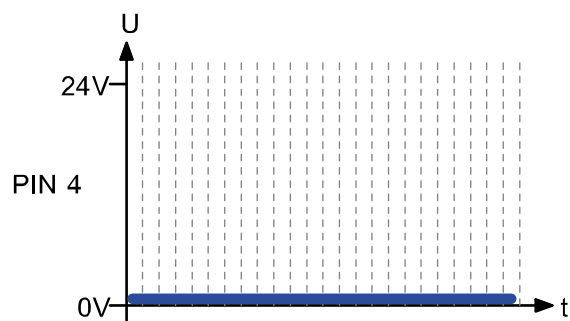

A permanent and continuous low signal (0 V) at PIN 4 indicates that the lubricator is ready for operation and that there are no active errors. The lubricator operates according to the settings made and delivers lubricant from the cartridge to the outlet accordingly.

### 7.3.4 Output signals / display messages – Time control when changing the factory settings

Different output of the error message is possible by changing the parameters  $E$  (error message),  $L$  (empty message),  $F$  (feedback) in advanced programming.

Inverting the error message  $E=1$  (high signal) to  $E=0$  (low signal) has a direct effect on the empty cartridge signal  $L$ . For the empty cartridge signal  $L$ , only parameterization  $L=0$  (low signal) and  $L=2$  (0.5 Hz square-wave signal) are possible.

Feedback signal  $F$  is dependent on parameter  $E$ . When inverting the error message from  $E=1$  to  $E=0$ , the controller returns a high signal for the duration of the dispensing process.

Settings			Output signal			Comment
E	L	F	E2 – E7	E1: Empty cartridge	Feedback – Motor run	
1	1	0	High	High	Low, permanent	Factory settings (If high = error or empty)
0	0	0	Low	Low	High, permanent	For alternative settings see the table Tbl - 17 (If low = error or empty)
1	1	1	High	High	High (10...18 sec.)	If >18 sec. high = error or empty
0	0	1	Low	Low	Low (10...18 sec.)	If >18 sec. low = error or empty
0	2	0	Low	0.5 Hz	High, permanent	-
0	2	1	Low	0.5 Hz	Low (10...18 sec.)	-
0	1	0	Low	Low	High, permanent	Same behavior as E0-L0-F0
0	1	1	Low	Low	Low (10...18 sec.)	Same behavior as E0-L0-F1

Tbl - 16 Output signals

Display	Designation	Output signal (PIN 4)	See chapter
OFF	Switched off	Low, permanent	6.1
On	Ready	High, permanent	7
01...50	Dispensing	High, permanent	7
E1	Empty cartridge	low, permanent or 0.5 Hz square-wave signal	7.3.2
E2	Cartridge error	Low, permanent	7.3.3
E3	Undervoltage	Low, permanent	7.3.3
E4/E5	Fatal error	Low, permanent	7.3.3
E7	Overload/overpressure	Low, permanent	7.3.3

Tbl - 17 Display messages at changed factory settings

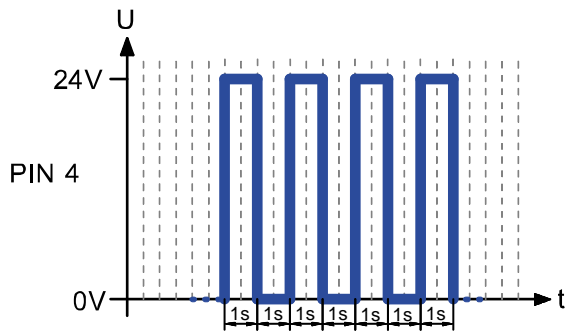
**7.3.5 Output signal 0.5 Hz square-wave signal at PIN 4**

Use of the output signal 0.5 Hz is independent of inversion of the output signals. In advanced programming, the empty cartridge signal *L* must be changed from the parameter value *L1* to *L2*.

The integrated microelectronics of the lubricator are equipped with an automatic counter of the number of delivery operations after fitting a new and full cartridge. For a cartridge with 125 cm<sup>3</sup> of lubricant, the number of strokes is 780; for a cartridge with 250 cm<sup>3</sup> of lubricant, the number of strokes is 1560. The low difference in calculation serves as protection against the ingress of air into the hydraulic system. If this signal is active, the lubricator does not deliver any lubricant!

- i Troubleshooting measures can be found in chapter 8.1.3 "Cartridge change".

## 8 Maintenance and disposal

- Before carrying out any maintenance or work, please note the general safety instructions (see chapter 2 "Safety") and observe all applicable local and operational safety regulations.
- Do not disable any protective device without authorization!

### 8.1 Maintenance schedule

The following maintenance schedule for the lubricator must be observed:

Maintenance	Commissioning	After 500 hours or after 3 months	Annually	If necessary
Visual inspection	X	X	X	X*
Cleaning	X	X	X	X*
Cartridge change	X**		X***	X*
* Depending on application conditions and lubricant consumption ** Depending on the delivery condition (ordered version) *** Recommended after 2 years at the latest				

Tbl - 18 Maintenance schedule.

#### 8.1.1 Visual inspection

- Check the entire lubrication system (lubricator and any connected accessories including lines and distribution) for external damage (e.g. loose lines) by careful visual inspection.
- Check the condition of the lubrication point for correct lubricant supply.
- Replace damaged or defective parts immediately to ensure a continuous and permanent lubrication.
- Check the fill level in the cartridge on the lubricator.
- Check any error messages at the lubricator and correct the causes respectively.

#### 8.1.2 Cleaning

- Clean the lubricator by suitable means (e.g. absorbent cloths) to remove dirt.

	NOTICE
	<p><b>Among other things, compressed air can lead to damage to the seals of the lubricator and to contamination of the lubricator or lubricant by dirt and particles.</b></p> <ul style="list-style-type: none"> <li>· Do not use compressed air for cleaning the lubricator.</li> </ul>

**8.1.3 Cartridge change**

	NOTICE
	<p><b>Already opened lubricant cartridges must not be reattached to the lubricator, as the integrated stroke counter is automatically reset after a cartridge is removed.</b></p> <ul style="list-style-type: none"> <li>· Always use full lubricant cartridges.</li> </ul>
	<p><b>Only use original lubricant cartridges with lubricants approved by WITTENSTEIN alpha GmbH.</b></p> <ul style="list-style-type: none"> <li>· Observe the maximum storage time of lubricants filled in cartridges.</li> </ul>
	<p><b>Refilling of empty or open lubricant cartridges is not possible.</b></p> <p><b>Make sure that the same lubricant is used in the new cartridge as already used before. Make sure that only cartridges with the same capacity are used.</b></p> <ul style="list-style-type: none"> <li>· Compare the specifications on the lubricant cartridge.</li> </ul>

The following table indicates the available lubricant cartridges:

Designation	Lubricant	Capacity	Material number
<b>LUE+125-05-1</b>	WITTENSTEIN alpha G11	125 cm <sup>3</sup>	20068231
<b>LUE+125-06-1</b>	WITTENSTEIN alpha G12	125 cm <sup>3</sup>	20068233
<b>LUE+125-07-1</b>	WITTENSTEIN alpha G13	125 cm <sup>3</sup>	20068236
<b>LUE+125-00-1</b>	Klüber Microlube GB0	125 cm <sup>3</sup>	20068238

Tbl - 19 Exchange cartridges.

Changing lubricant cartridges at the lubricator is easy and only requires two steps.

The cartridge only needs to be changed if it is empty or if the useful life of the lubricant was exceeded. Cartridges can be changed during normal operation of the lubricator. Besides changing the cartridge, no additional measures are necessary!

Ü A malfunction has occurred at the lubricator (error *E1*); the red LED flashes every 5 seconds to visually indicate an error.

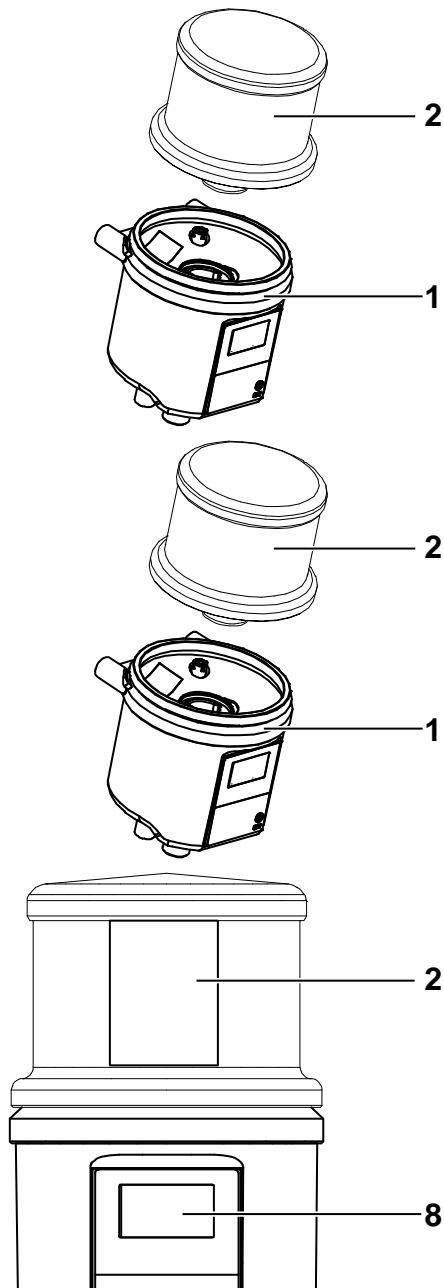

### Unscrew the empty cartridge of the lubricator.

- Turn the empty cartridge [2] counter-clockwise to remove it from the lubricator [1] and dispose of it in compliance with applicable regulations.
- i Ensure that the work is carried out under clean conditions. Dirt and particles must not enter the lubricant inlet. If necessary, clean before you start working (chapter 8.1.2 "Cleaning").

### Connection of the new lubricant cartridge.

- Set the full lubricant cartridge [2] on the lubricator [1].
- Turn the lubricant cartridge clockwise to tighten it to the lubricator.
- i The final position is reached after two full turns if the label of the lubricant cartridge [2] is aligned flush with the front cover [8] of the lubricator.

- Ü If error *E1* was shown on the display before the cartridge was changed, the display goes out and the red LED flashes every 5 seconds. Separate acknowledgment is not required. The green LED flashes briefly every 5 seconds.
- Ü After completion, the lubricator automatically returns to the last active mode (On/OFF).
- i If the empty cartridge (error *E1*) occurred during a dispensing cycle (delivery), it is automatically interrupted and continued after the work is completed.

## 8.2 Recommissioning

- Reinstall all safeguards and make sure that all tools have been removed from the hazard area.
- Make sure that the lubricator is activated.

## 8.3 Disposal

- For disposal of the lubricator as well as any empty or opened cartridges, applicable national regulations must be observed.
- For disposal, the respective safety data sheets and disposal instructions for the individual components must be observed.

- i Refilling of empty lubricant cartridges is not possible.



## 9 Appendix

### 9.1 EC/EU declaration of conformity

**DLS**

SCHMIERSYSTEME

DIRECT LUBRICATION SYSTEMS

**Declaration of EG conformity**

According to the Machinery Directive 2006/42/EG of 2006, May 17th



Herewith the manufacturer  
DLS Schmiersysteme GmbH; Gewerbering 5; D-82140 Olching  
Declare that the following lubricating system

**FlexxPump 125 (24V DC)**

Delivered by us, concerning design and construction as well as the model put into circulation, comply with the EG directives 2006/42/EG. In particular, the following harmonized standards were applied:

EN 12100:2011-03 Safety of machinery

**According to the EG directive on Electromagnetic Compatibility 2014/30/EU**

The manufacturer herewith declares that the following lubrication system

**FlexxPump 125 (24V DC)**

Delivered by us, concerning design and construction as well as the model put into circulation, comply with the above-mentioned EU directive. In particular, the following harmonized standards were applied:

EN 61000-6-2, EN 61000-6-4 Electromagnetic Compatibility (EMC)

Authorized representative for the compilation of technical documentation:

Reiner Hochholzer  
Geschäftsführer  
DLS Schmiersysteme GmbH  
Gewerbering 5  
D-82140 Olching

Olching, 18.02.2020



Reiner Hochholzer, Geschäftsführer

DLS Schmiersysteme GmbH  
Gewerbering 5  
D-82140 Olching  
+49 8142 650 690  
+49 8142 650 6929  
www.dls-schmiersysteme.de

## Revision history

Revision	Date	Comment	Chapter
01	03/17/2022	New version	All



alpha

WITTENSTEIN alpha GmbH · Walter-Wittenstein-Straße 1 · 97999 Igersheim · Germany  
Tel. +49 7931 493-12900 · [info@wittenstein.de](mailto:info@wittenstein.de)

**WITTENSTEIN – one with the future**  
[www.wittenstein-alpha.de](http://www.wittenstein-alpha.de)