

Operating manual

## Lubricator

LUC+125 impulse-controlled



**Sales department**
**WITTENSTEIN alpha GmbH**

Walter-Wittenstein-Straße 1  
D-97999 Igersheim  
Germany

**Customer Service department**

In the event of technical questions, contact the following address:

		✉	☎
Deutschland	WITTENSTEIN alpha GmbH	service@wittenstein-alpha.de	+49 7931 493-12900
Benelux	WITTENSTEIN BVBA	service@wittenstein.biz	+32 9 326 73 80
Brasil	WITTENSTEIN do Brasil	vendas@wittenstein.com.br	+55 15 3411 6454
中国	威腾斯坦（杭州）实业有限公司	service@wittenstein.cn	+86 571 8869 5856
Österreich	WITTENSTEIN GmbH	office@wittenstein.at	+43 2256 65632-0
Danmark	WITTENSTEIN AB	info@wittenstein.dk	+45 4027 4151
France	WITTENSTEIN sarl	info@wittenstein.fr	+33 134 17 90 95
Great Britain	WITTENSTEIN Ltd.	sales.uk@wittenstein.co.uk	+44 1782 286 427
Italia	WITTENSTEIN S.P.A.	info@wittenstein.it	+39 02 241357-1
日本	ヴィッテンシュタイン株式会社	sales@wittenstein.jp	+81-3-6680-2835
North America	WITTENSTEIN holding Corp.	technicalsupport@wittenstein-us.com	+1 630-540-5300
España	WITTENSTEIN S.L.U.	info@wittenstein.es	+34 93 479 1305
Sverige	WITTENSTEIN AB	info@wittenstein.se	+46 40-26 50 10
Schweiz	WITTENSTEIN AG Schweiz	sales@wittenstein.ch	+41 81 300 10 30
台湾	威腾斯坦有限公司	info@wittenstein.tw	+886 3 287 0191
Türkiye	WITTENSTEIN Güç Aktarma Sistemleri Tic. Ltd. Şti.	info@wittenstein.com.tr	+90 216 709 21 23

**Copyright**

© **WITTENSTEIN alpha GmbH 2022** reserves all rights for layout and corporate design.

© **DLS Schmiersysteme GmbH 2022** reserves all rights for content and text.

This documentation is protected by copyright.

**WITTENSTEIN alpha GmbH** and **DLS Schmiersysteme GmbH** reserve all rights to photo-mechanical reproduction, copying, and the distribution by special processes (such as computers, file media, data networks), in whole or in part.

Subject to technical and content changes without notice.

## Table of contents

<b>1</b>	<b>About this manual .....</b>	<b>3</b>
1.1	Information symbols and cross references .....	3
1.2	Scope of delivery .....	3
<b>2</b>	<b>Safety .....</b>	<b>3</b>
2.1	EC/EU Directive.....	3
2.2	Personnel .....	3
2.3	Intended use.....	4
2.4	Reasonably foreseeable misuse .....	4
2.5	Guarantee and liability .....	4
2.6	General safety instructions .....	5
2.7	Structure of warning instructions .....	5
2.7.1	Safety symbols .....	5
2.7.2	Signal words.....	6
<b>3</b>	<b>Description of the lubricator.....</b>	<b>7</b>
3.1	Overview of lubricator components .....	7
3.2	Name plate and labeling.....	7
3.3	Marking.....	8
3.4	Ordering codes .....	8
3.5	Dimensions.....	8
3.6	Scope of delivery .....	8
3.7	Technical data .....	9
3.8	Lubricants.....	10
3.9	Cord lengths .....	10
<b>4</b>	<b>Transport and storage.....</b>	<b>10</b>
4.1	Transport .....	10
4.2	Storage .....	10
<b>5</b>	<b>Assembly.....</b>	<b>11</b>
5.1	Preparations .....	11
5.2	Mounting the lubricator .....	11
5.3	Connecting the prefilled hose .....	12
5.4	Electrical interface connection.....	12
<b>6</b>	<b>Startup and operation .....</b>	<b>13</b>
6.1	Switching on the lubricator .....	13
6.2	Operation and settings .....	13
6.2.1	General.....	13
6.2.2	Factory settings .....	14
6.2.3	Default settings in impulse mode .....	14
6.3	Menu and display messages .....	14
6.4	Error messages .....	15

<b>7</b>	<b>Input and output signals – external control system (PLC)</b> .....	<b>17</b>
7.1	Pin assignment – external control system (PLC) .....	17
7.2	Input signals – external control system (PLC) .....	18
7.2.1	2-second control signal.....	19
7.2.2	3-second control signal.....	21
7.2.3	12-second control signal.....	23
7.2.4	10-second control signal.....	25
7.3	Output signals / Display messages – external control system (PLC) .....	26
7.3.1	Error <i>E1</i> (empty cartridge) – external control system (PLC).....	27
7.3.2	Error <i>E2</i> (cartridge error) – external control system (PLC) .....	29
7.3.3	Error <i>E3</i> (undervoltage) – external control system (PLC).....	30
7.3.4	Error <i>E4</i> / <i>E5</i> (fatal error) – external control system (PLC).....	31
7.3.5	Error <i>E7</i> (overload) – external control system (PLC).....	32
<b>8</b>	<b>Maintenance and disposal</b> .....	<b>33</b>
8.1	Maintenance schedule .....	33
8.1.1	Visual inspection.....	33
8.1.2	Cleaning .....	33
8.1.3	Cartridge change .....	34
8.2	Recommissioning .....	35
8.3	Disposal .....	35
<b>9</b>	<b>Appendix</b> .....	<b>36</b>
9.1	EC/EU declaration of conformity.....	36

## 1 About this manual

This manual contains information which is necessary for the safe use of the LUC+125 (FlexxPump 125), version 24 V-DC (impulse-controlled), hereinafter referred to as lubricator.

If this manual is supplied with amendment sheets (e.g. for special applications), then the information in the amendment is valid. Contradictory specifications in this manual are therefore void.

The user should contact **WITTENSTEIN alpha GmbH** with any questions about special applications. The actual operator must guarantee and ensure that this manual including any amendments are read and understood by all persons assigned to install, operate, or maintain the lubricator. For this reason, keep this manual in a suitable and ideally accessible location near the lubricator.

Inform colleagues who work in the area around the machine about the safety instructions so that no one sustains injuries.

The original was written in German, all other language versions are translations of the original manual.

### 1.1 Information symbols and cross references

The following information symbols are used:

- Indicates an action to be performed
- Ü Indicates the results of an action
- i Provides additional handling information

A cross reference refers to the chapter number and the header of the target section (e.g. 2.3 "Intended use").

A cross reference to a table refers to the table number (e.g. Table "Tbl - 1").

### 1.2 Scope of delivery

- Check the completeness of the delivery against the delivery note.
- i Immediately notify the carrier, the insurance company, or **WITTENSTEIN alpha GmbH** in writing of any missing parts or damage.

## 2 Safety

This manual, especially the safety instructions and the rules and regulations valid for the operating site, must be observed by all persons working with the lubricator. General legal rules and regulations as well as applicable rules and regulations on prevention of accidents [e.g. personal protective equipment (PPE)] and environmental protection must be observed.

### 2.1 EC/EU Directive

In scope of the EC/EU Directive, commissioning (recommissioning) of a machine at which the lubricator was installed and/or attached is prohibited until it is verified that the machine complies with all provisions of the applicable regulation.

An EC/EU declaration of conformity for this lubricator can be found in the appendix (see chapter 9.1 "EC/EU declaration of conformity").

### 2.2 Personnel

Only technicians who have read and understood this operating manual may perform work on the lubricator. Local and/or company regulations apply accordingly.

## 2.3 Intended use

For the intended use of the lubricator, the following points must be observed:

- The lubricator is approved only for industrial applications.
- The lubricator may only be put into operation according to the technical specifications (see chapter 3.7 "Technical data").
- Unauthorized modifications to the lubricator are not permitted.
- Read and observe the operating manual.
- During operation of the lubricator, regular visual inspections must be carried out at the lubricator itself as well as the lubrication point. Any irregularities and their cause must be corrected immediately.
- The cartridge must not be refilled.
- The lubricator must not be opened or dismantled.
- Only lubricants which are approved by **WITTENSTEIN alpha GmbH** may be used.
- Applicable rules and regulations on occupational safety, prevention of accidents and environmental protection must be observed.
- Any works or tasks with or at the lubricator may only be carried out with authorization (see chapter 2.2 "Personnel").

Any use other than the previously described intended use or non-compliance with one of the points specified above is regarded misuse. In this case no liability or warranty claims will be assumed.

## 2.4 Reasonably foreseeable misuse

Any usage of the lubricator that exceeds the maximum permitted technical data is considered misuse and is therefore prohibited.

## 2.5 Guarantee and liability

Any guarantee and liability claims are excluded for personal injury and/or material damage in case of:

- Ignoring the information on transport and storage;
- Misuse;
- Improper or not carried out maintenance and repair;
- Incorrect assembly / disassembly or incorrect operation;
- Operation of the lubricator when safety devices and equipment are defective;
- Operation of the lubricator without lubricant;
- Operation of the lubricator with non-approved lubricant;
- Operation of a heavily contaminated lubricator;
- Modifications or changes without written approval by **WITTENSTEIN alpha GmbH**;
- Opening and/or partly or complete dismantling of the lubricator.

## 2.6 General safety instructions

The operation of the lubricator involves remaining risks even when adhering to the intended use. **Defective or faulty electrical connections or unapproved, current-carrying components** can cause serious injuries and even death.

- Have all electrical connection work performed by qualified technicians only.
- Immediately replace damaged cords or plugs.

**Loose or overtightened screw connections** can cause damage to the lubricator:

- Mount and check all screw connections according to the specified admissible tightening torques. Use a calibrated torque wrench.

**Lubricants** are flammable, can cause skin irritation, and can contaminate soil and water:

- In case of fire, do not use a jet of water to extinguish.
- In case of fire, only use suitable extinguishing agents such as powder, foam or carbon dioxide.
- Always observe the applicable safety instructions by the lubricant manufacturer on the safety data sheet of the used lubricant.
- Use protective gloves to avoid direct skin contact with lubricants.
- Use and dispose of lubricants properly.

## 2.7 Structure of warning instructions

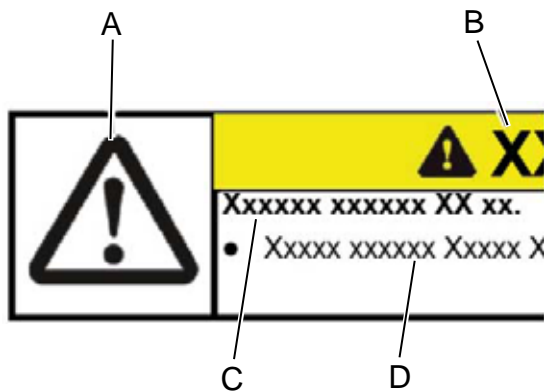

Warning instructions are situation-specific. They will be precisely where tasks are described in which dangers can arise.

The warning instructions in this manual are designed according to the following pattern:

- A** = safety symbol
- B** = signal word
- C** = Type and consequence of the danger
- D** = Avoiding the danger

### 2.7.1 Safety symbols

The following safety symbols are used to indicate hazards, prohibitions and important information:



General danger



Electric voltage



Flammable



Environment

2.7.2 Signal words

	<p style="text-align: center;"><b>⚠ DANGER</b></p> <p>This signal word indicates an imminent danger that will cause serious injuries or even death.</p>
	<p style="text-align: center;"><b>⚠ WARNING</b></p> <p>This signal word indicates a potential hazard that could cause serious injuries and even death.</p>
	<p style="text-align: center;"><b>⚠ CAUTION</b></p> <p>This signal word indicates a potential hazard that could cause minor or serious injuries.</p>
	<p style="text-align: center;"><b>NOTICE</b></p> <p>This signal word indicates a potential hazard that could lead to property damage.</p>



### 3 Description of the lubricator

The lubricator is designed as a highly compact double piston pump for grease as lubricant. The two pistons run force-controlled and in opposing directions. They are both connected to the same outlet. The outlet is secured by an integrated check valve. At each dispensing cycle, approx. 0.15 cm<sup>3</sup> of lubricant are dispensed. Multiple subsequent dispensing processes can be set.

The lubricator must be integrated in an external control system (e.g. PLC). The lubricator features an electrical interface for control. By means of output signals, the lubricator also enables remote monitoring for querying of the status and any potential error messages (e.g. empty cartridge). The lubricator is controlled via various input signals processed by microelectronics to ensure ideal supply of lubricants to lubrication points.

The different operating statuses are displayed at the front as well as other additional information (e.g. errors).

#### 3.1 Overview of lubricator components

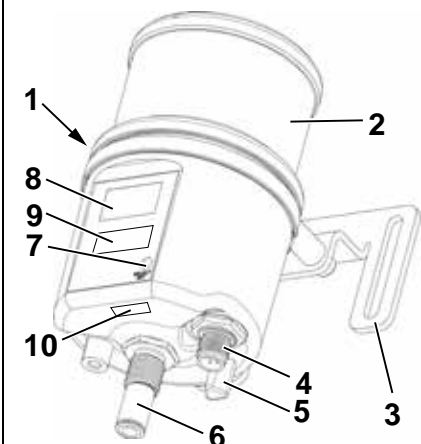
	Pos.	Designation
	1	LUC+125, 24 V impulse-controlled
	2	Exchange cartridge LUE+125
	3	Assembly bracket
	4	Interface M12x1, 4-pole
	5	Magnetic pen (in holder)
	6	Hose connection
	7	Action field
	8	Display
	9	Name plate
	10	CE symbol

Tbl - 1 Overview of lubricator components

#### 3.2 Name plate and labeling

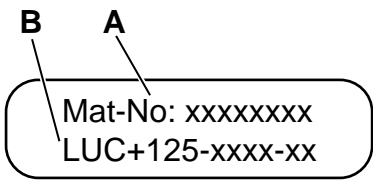
	Pos.	Designation
	A	Material number
	B	Ordering codes (see chapter 3.4 "Ordering codes")

Tbl - 2 Name plate

### 3.3 Marking

The CE mark is attached to the lubricator housing. The position of the CE mark is described in chapter 3.1 "Overview of lubricator components".

#### Manufacturer

DLS Schmiersysteme GmbH  
 Gewerbering 5  
 82140 Olching, Germany  
 Tel.: +49-(0)8142-65069-0  
 Fax: +49-(0)8142-65069-29  
 Email: mail@DLS-Schmiersysteme.de  
 www.DLS-Schmiersysteme.de

### 3.4 Ordering codes

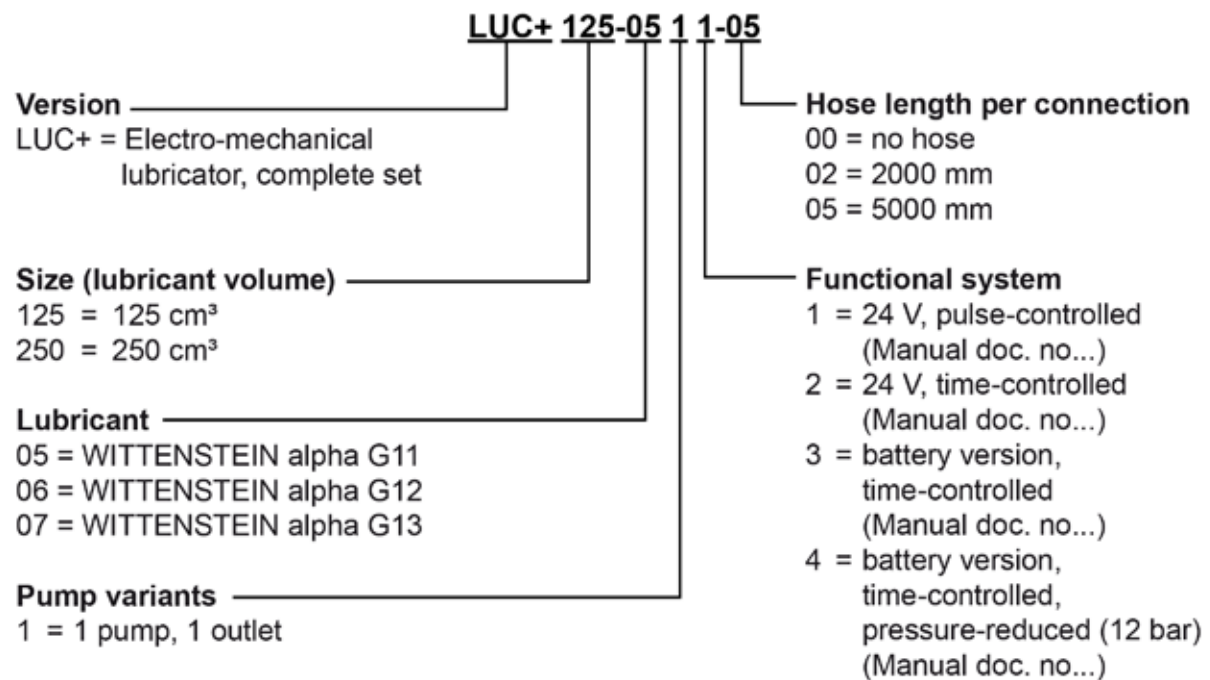

### 3.5 Dimensions

Dimensions can be found

- in our catalog,
- under [www.wittenstein-alpha.de](http://www.wittenstein-alpha.de).

CAD data and dimension sheets are available upon request.

### 3.6 Scope of delivery

The lubricator is available in different versions. They can be distinguished by the execution, the lubricant filling as well as the included accessories.

### 3.7 Technical data

Housing		
Dimensions without cartridge	83 x 96 x 85 (W x H x D)	mm
Dimensions with cartridge 125 cm <sup>3</sup>	83 x 154 x 85 (W x H x D)	mm
Dimensions with cartridge 250 cm <sup>3</sup>	83 x 188 x 85 (W x H x D)	mm
Weight (without cartridge)	approx. 350	g
Assembly option	Assembly bracket with slotted holes pre-assembled. Bottom side: IG M5 (3 Nm)	
Mounting position	vertically	
Housing material	PA 6.6 GF30 / POM	
Outlet material	Stainless steel	
Operating temperature *	0 ... +60	°C
Lubricant and hydraulics		
Cartridge volume	125 or 250	cm <sup>3</sup>
Lubricant properties	Grease up to NLGI, class 2	
No. of outlets	1	
Hydraulic connection	PA hose	
Number of lubrication points	Up to 8 in combination with aluminum progressive distribution **	
Max. pressure	50 (-10%/+15%)	bar
Dispensed volume	Per stroke 0.15 (-5%)	cm <sup>3</sup>
Electrics		
Display	Display	
Operating voltage (DC)	24 (20V...28V)	V
Fuse protection	0.75 (slow)	A
Protection class	IP 54	
Power consumption	$I_{\max} < 0.3$ $I_{\text{bias}} < 0.025$	A
For further information on the electrical system, see chapter 7 "Input and output signals – external control system (PLC)"!		
* Depending on the lubricant used		
* The specified value depends on the actual application and may deviate in individual cases depending on the used lubricant and other conditions.		

Tbl - 3 Technical data

### 3.8 Lubricants

Only use lubricants approved by **WITTENSTEIN alpha GmbH** in dedicated original cartridges exclusively developed for the lubricator.

**The lubricants used depend on the individual application. The respective designation can be found on the label of the cartridge.**

For further information about lubricants, documentation and safety data sheets, please contact **WITTENSTEIN alpha GmbH** directly.

### 3.9 Cord lengths

In general, the lubricator should be installed as closely as possible to the device to be supplied (lubrication point). Ideally, this should be directly at the lubrication point. If this is not possible due to space restrictions or reasons regarding accessibility, cords can be used between the lubricator and the lubrication point (e.g. distribution).

The maximum hose length depends on the temperature as well as the used grease, hoses and accessories.

## 4 Transport and storage

The lubricator is delivered in an outer packaging (cardboard box) and with a lubricant cartridge and other accessories in the same shipment. For protection against humidity and dirt, it is additionally packaged in PE foil. To prevent leakage of the prefilled lubricant from the lubricator, protective caps are installed at the lubricant inlet and outlet.

Dispose of the packaging materials at the recycling sites designated for this purpose in compliance with applicable national and operational regulations.

After receipt of the lubricator, check the completeness of the delivery against the delivery note.

Immediately notify the carrier, the insurance company, or **WITTENSTEIN alpha GmbH** in writing of any potentially missing parts or damage.

### 4.1 Transport

	<b>NOTICE</b>
<p><b>Hard shocks, for instance because of falling or hard dropping, can damage the lubricator.</b></p> <ul style="list-style-type: none"> <li>· Do not throw the lubricator.</li> </ul>	

### 4.2 Storage

Store the lubricator in its original packaging in vertical position under dry, frost-protected conditions at an ambient temperature of +5°C to +30°C. The maximum unopened storage time is 2 years.

For storage logistics, the "First-In-First-Out principle" (FiFo) is recommended.

## 5 Assembly

The lubricator is delivered with an inserted lubricant cartridge in vented condition as a ready-to-install component with an installed assembly bracket. The outlet is sealed with a yellow cap. The provided hose lines have already been prefilled with the respective lubricant.

### 5.1 Preparations

	NOTICE
	<p><b>Among other things, compressed air can lead to damage to the seals of the lubricator and to contamination of the lubricator or lubricant by dirt and particles.</b></p> <ul style="list-style-type: none"> <li>· Do not use compressed air.</li> <li>· Make sure that the assembly location is not considerably contaminated.</li> </ul>

### 5.2 Mounting the lubricator

	<ul style="list-style-type: none"> <li>· Observe the safety and processing instructions for the threadlocker to be used.</li> </ul>
--	---

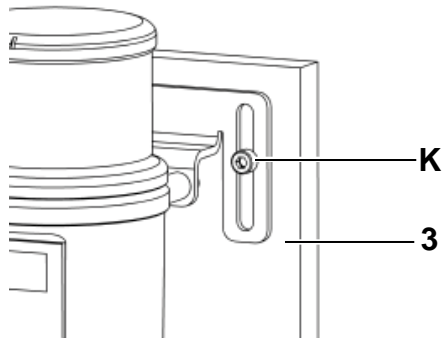

- Apply threadlocker (e.g. LOCTITE® 243) to the fastening screws [K].
- Install the lubricator with the pre-assembled assembly brackets [3] at the intended position. The slotted holes enable fine adjustment of the installation height.
- i The prescribed screw sizes and tightening torques can be found in the table "Tbl - 4".

Hole spacing [mm]	Quantity x diameter [ ] x [mm]	For screw size / property class	Tightening torque [Nm]
95	2 x 6.6	M6 / 8.8	9.0

Tbl - 4 Through-holes in assembly bracket

### 5.3 Connecting the prefilled hose

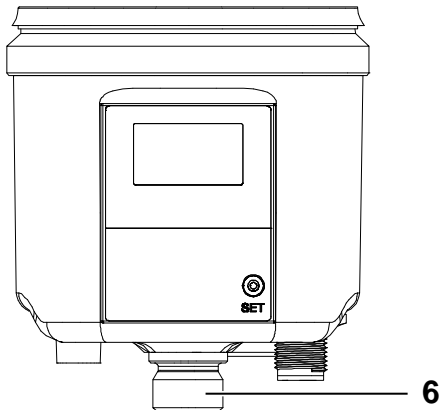

- Remove the yellow closing cap.
- Screw in the provided hose connection [6].
  - i Max. tightening torque 2 Nm.
- Establish the hydraulic connection between the distributor and the lubricator [6]. Ensure that hoses and connection elements are tight and properly assembled.
  - i If possible, use the prefilled hoses included in the scope of delivery with the respective lubricant!

- i Further important instructions on how to connect the hose can be found in the separate manual "Prefilled high pressure hose" (doc. no. 2098-D072334). The manual is included in the scope of delivery of the hose or is available on request from **WITTENSTEIN alpha GmbH**. Always state the material number when doing so.

### 5.4 Electrical interface connection

	⚠ DANGER
<p><b>Defective or faulty electrical connections or unapproved, current-carrying components can cause serious injuries and even death.</b></p> <ul style="list-style-type: none"> <li>· Have all electrical connection work performed by qualified technicians only.</li> <li>· Immediately replace damaged cords or plugs.</li> <li>· Observe the five safety rules of electrical engineering before starting electrical installation work:                     <ul style="list-style-type: none"> <li>- Switch off the power supply.</li> <li>- Secure against unintended reactivation.</li> <li>- Check that there is no voltage.</li> <li>- Ground and short-circuit.</li> <li>- Cover adjacent and electrified parts.</li> </ul> </li> </ul>	

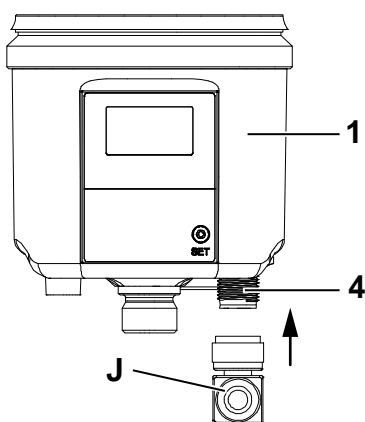

- Connect the lubricator [1] to the external power supply or control system with a suitable connection cord [J] via the M12x1 interface [4] at the bottom of the lubricator.
- i Depending on the application, connection cords with straight or angled socket can be used.
- i **For the properties of the connection cable, please refer to chapter 7.1 "Pin assignment – external control system (PLC)".**

## 6 Startup and operation

- Read the general safety instructions before beginning to work (see chapter 2.6 "General safety instructions").
- Make sure that the lubricator is properly and fully assembled. In particular, the power supply must be connected, and a lubricant cartridge must be attached.

### 6.1 Switching on the lubricator

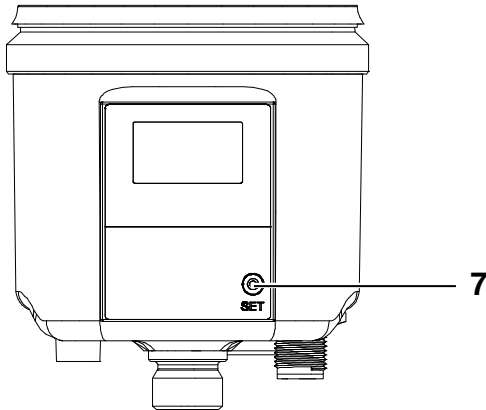

- Hold the magnetic pen against the action field [7].
- Ü The LED flashes red three times.
- Immediately remove the magnet pen when *On* is displayed.
- Ü The firmware information is displayed.
- Ü The lubricator flashes, is in operation and *PAU* is displayed.

The lubricator is supplied from the factory in a vented state. If it is necessary to vent further, a detailed description on this can be found in chapter 7.2.3 "12-second control signal". Afterwards, the lubricator executes a specific number of strokes to convey the lubricant from the cartridge to the outlet.

## 6.2 Operation and settings

### 6.2.1 General

What you should know about operation and setting of the lubricator:

- The lubricator is designed as an individual lubricator for one lubrication point. Depending on the actual application case, however, the lubricator can also be used for reliable grease supply to several lubrication points. This can be achieved by connecting parts of the system accessories (e.g. progressive distributors) to the lubricator. In such a case, it may be necessary to change the settings at the lubricator to ensure safe and reliable operation.
- For operation and control, the lubricator must be integrated into a control system (PLC).
- The single-use changeable cartridges with a lubricant capacity of 125 or 250 cm<sup>3</sup> ensure controlled and consistent quality of lubricants and are filled without any trapped air. The lubricator offers a reliable supply to lubrication points and prevents downtime of machinery. This version of the lubricator is designed for grease lubricants.
- The lubricator **cannot** be used without an external 24 V DC power supply. The lubricant cartridge is included in the scope of delivery and already installed in the lubricator.
- The respective conditions of the lubricator are shown on the display, which also enables recognition of the status by LEDs in different colors.
- In case of any questions regarding your applications and the correct settings for the lubricator, please contact **WITTENSTEIN alpha GmbH**.

### 6.2.2 Factory settings

Parameter	Designation	Factory settings	Result
P	Maximum pressure	50	50 bar
C	Number of cycles	1	0.15 cm <sup>3</sup> / stroke
Pu	Control mode	1	Impulse mode active
U	Cartridge size	12	Cartridge 125 cm <sup>3</sup>
E	Inverted output signals	0	Permanent low signal in case of error
L	Empty cartridge signal	2	Square-wave signal
F	Feedback signal	1	HIGH Signal

**The factory settings may only be changed after consultation.**

**If you have any questions, please contact WITTENSTEIN alpha GmbH Sales / Customer Service.**

Tbl - 5 Factory settings

### 6.2.3 Default settings in impulse mode

In impulse mode, the lubricator must be integrated into a control system (PLC) for operation and control. Depending on the signals received from the external control system (PLC), one or several strokes are executed by the lubricator to dispense lubricant (0.15 cm<sup>3</sup> per stroke).

- i To use the lubricator, it must first be properly assembled and installed, and afterwards activated. For lubricator assembly, see chapter 5 "Assembly".
- i For special versions of the lubricator, the dedicated instructions and information on the provided note must be observed!

### 6.3 Menu and display messages

The display of the lubricator is used to show various kinds of information to the user.

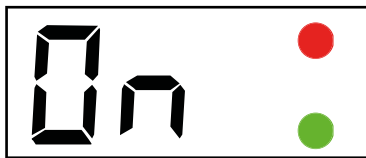
Symbol	Designation	Notice
	Display information	The display visually shows information both during operation and for programming.

Tbl - 6 Display information

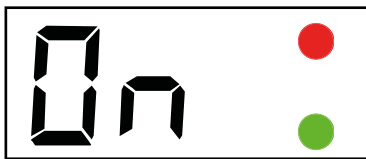
Display	Assignment
	Top LED: red
	Bottom LED: green

Tbl - 7 LED assignment



Information in display	Meaning	See chapter
No display	Power supply not connected	6.2
OFF	Lubricator switched off	6.2
ON	Lubricator ready for operation	6.2
PAU	Lubricator in impulse mode <i>PAU</i> ready for operation and waiting for control signal from the external control system (PLC)	7
PAU (flashing)	Lubricator receives a control signal from the external control system (PLC)	7
'...'	Received control signal longer than 15 seconds	7.2
E1	Error <i>E1</i> (empty cartridge)	6.4
E2	Error <i>E2</i> (cartridge error / no cartridge fitted)	6.4
E3	Error <i>E3</i> (undervoltage)	6.4
E4/E5	Error <i>E4/E5</i> (fatal error)	6.4
E7	Error <i>E7</i> (overload)	6.4
01 ... 50	After each cycle, the maximum applied counterpressure during the cycle is displayed in bar.	

Tbl - 8 Display messages

## 6.4 Error messages

The status is permanently monitored by the microelectronics integrated in the lubricator. In case of any irregularities, an addressed error message is issued and shown on the display. The red LED flashes every 5 seconds to visually indicate an error.

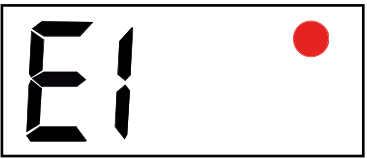
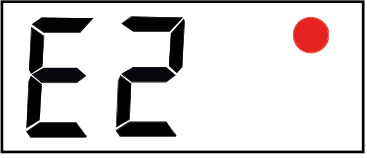
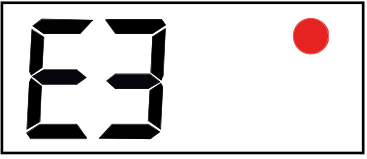
Display	Fault	Explanation	Remedy
	E1	Cartridge empty	<ul style="list-style-type: none"> <li>· Place a new cartridge on the lubricator (see chapter 8.1.3 "Cartridge change").</li> <li>i No need to acknowledge the error; it is automatically cleared after the corrective action is performed.</li> </ul>
	E2	Cartridge error; cartridge not recognized or incorrectly fitted	
	E3	Undervoltage	<ul style="list-style-type: none"> <li>· Check the power supply of the lubricator</li> </ul>

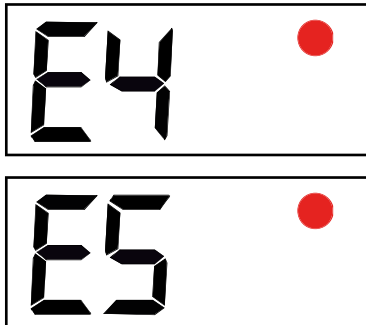
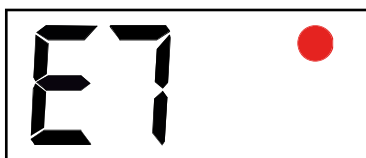
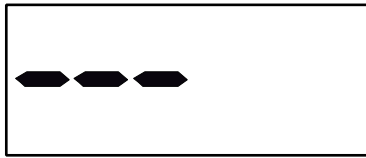
Display	Fault	Explanation	Remedy
	E4/E5	Fatal error	<p>The error <i>E4/E5</i> can have different causes:</p> <ul style="list-style-type: none"> <li>- Increased voltage for a short time, 28...30 V, and therefore the motor runtime is too short.</li> <li>- The connected supply voltage was too low and the motor runtime too long.</li> </ul> <p>· In these cases, the error is corrected by switching the lubricator off and on again.</p> <p><b>Important!</b> Between switching the lubricator off and on, 60 seconds must elapse.</p> <ul style="list-style-type: none"> <li>· If the error <i>E4 / E5</i> still persists, remove the lubricator from the application and return it with the lubricant cartridge and a description of the error to <b>WITTENSTEIN alpha GmbH</b> for investigation.</li> </ul>
	E7	Overload; the counterpressure at the lubrication point is too high	<ul style="list-style-type: none"> <li>· Check the lubrication point and eliminate the cause.</li> </ul>
	'---'	Received control signal longer than 15 seconds	Only use high signals within the prescribed tolerances (chapter 7.2 "Input signals – external control system (PLC)").

Tbl - 9 Malfunctions

- i The lubricator is controlled and monitored via an external control system (PLC). When an error occurs, the differentiated error messages are sent to the PLC for errors *E1 ... E7* transmitted as output signals via PIN 4 of the electrical interface of the lubricator (see chapter 7.3 "Output signals / Display messages – external control system (PLC) ").

## 7 Input and output signals – external control system (PLC)

The lubricator only works as pulse-controlled lubrication system if unchangeable input signals (high-signal) are transmitted in a defined order from the PLC to the lubricator via PIN 2. Via high/low signals picked up at PIN 4, the lubricator indicates the respective status to the PLC and enables comprehensive control and differentiated evaluation of the different conditions by suitable programming of the PLC. For incorporation of the lubricator into an external control system, one input and one output must be provided on the control side.

### 7.1 Pin assignment – external control system (PLC)

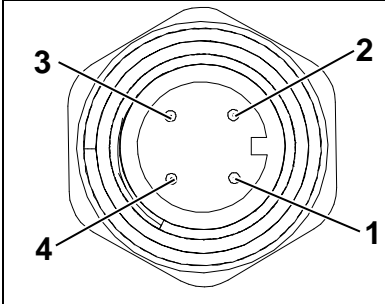
	PIN	Assignment	Color
	1	+24 V DC	Brown
	2	Input signal PLC => FP 125	White
	3	Ground (GND)	Blue
	4	Lubricator output signal => PLC	Black
Type: M12x1 plug socket; 4-pin, A-coded			

Tbl - 10 PIN assignment – external control system (PLC)

For electrical connection to the external control (PLC) of an equipment, the lubricator is equipped with a 4-pin plug socket in the form of a connector with standard M12x1 port.

- i In impulse mode, the lubricator can be fully shut down by disconnecting the supply voltage. The settings made are not lost. After reconnection of the supply voltage, the lubricator executes a self-test and resumes its function after receipt of an input signal from the PLC.
- i For operation of the lubricator via an external control system (PLC), a program corresponding to the communication protocol must be created in the PLC.
- i The output signal at PIN 4 can be used for further processing (e.g. indicator light or external control system). The maximum admissible output current of  $I_{max} < 20$  mA must not be exceeded. Inductive loads (e.g. relays) must not be connected!
- i After extended standstill of the lubricator, a test run should be carried out manually. To do so, a specific number of dispensing processes can be executed via the PLC (see chapter 7.2 "Input signals – external control system (PLC)").

## 7.2 Input signals – external control system (PLC)

The lubricator provides the following unchangeable defined control signals (input signals), which must be transmitted by the PLC to the lubricator via PIN 2 of the electrical M12x1 interface as high signal (+24 V DC).

The control signals must be generated by the external control system (PLC) as high signal (+24 V) via specific times, each with a tolerance of +/- 0.1s

Signal duration in seconds	Designation	Function	See chapter
<b>2 high</b>	2-second signal	1 stroke	7.2.1
<b>3 high</b>	3-second signal	2 strokes	7.2.2
<b>12 high</b>	12-second signal	FIL function	7.2.3
<b>10 high</b>	10-second signal	Error acknowledgment	7.2.4

Tbl - 11 Signal durations

- i The lubricator only processes the control signals specified in the table up to a maximum length of 12 seconds. In case of a high signal (+24 V DC) outside of the tolerance, there is no reaction from the lubricator. In case of a high signal (+24 V DC) for more than 15 seconds at PIN 2 of the electrical interface, --- is shown in the display and there is no reaction from the lubricator.

**7.2.1 2-second control signal**

The 2-second control signal triggers one single dispensing process. After a pause time of at least 22 seconds, this control signal can be repeated, or a different control signal can be transmitted. The lubricator reacts to control signals at PIN 2 only in a specific operating status. The operating conditions are transmitted by the lubricator via PIN 4 as high/low signal and must be picked up and processed accordingly in the PLC.

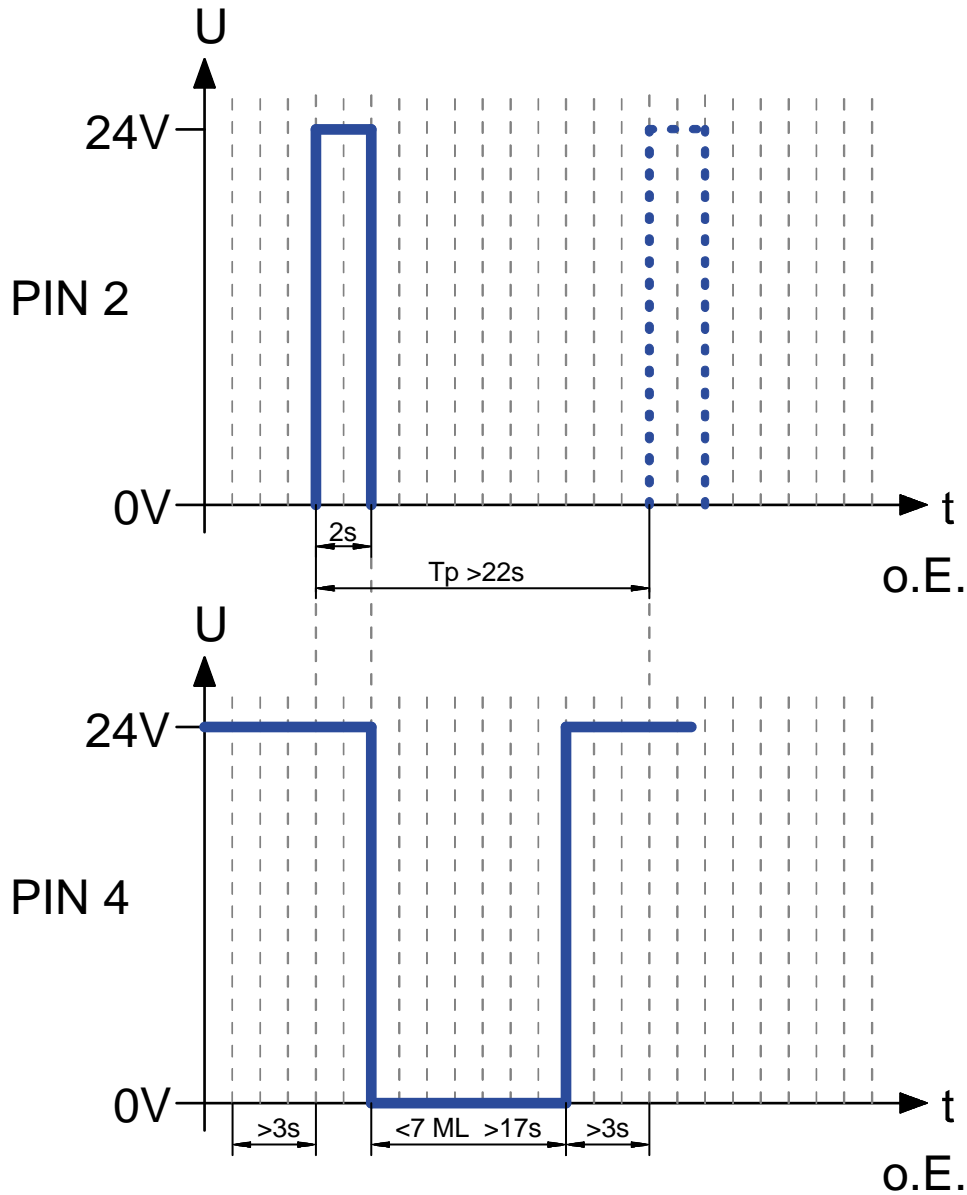

Tp: pause time  
MR: motor run

**Description:**

- Ü The lubricator is properly connected both to an external control system via the electrical interface and to the voltage supply.
- Ü If impulse mode is activated at the lubricator, *PAU* is shown on the display.
- Ü There are no errors on the lubricator; the lubricator is ready for operation; the green LED on the display flashes once every 5 seconds.

The lubricator sends a permanent output signal (high level) to PIN 4 indicating readiness to the external control system (PLC). This output signal must be active permanently and without interruption for >3 seconds. Activation by an external control system is possible only if this condition is met.

- The 2-second control signal with a signal duration of 2 (1.9 ... 2.1) seconds high signal can be sent to the lubricator from the external control system (PLC).
- Ü While there is a high input signal from the external control system (PLC) at PIN 2 of the lubricator, *PAU* is shown flashing on the display.

Directly after release of the signal the motor run (MR) of the lubricator is started and 0.15 cm<sup>3</sup> of lubricant is conveyed to the outlet. At the same time as the start of motor run (MR), a low output signal is sent for confirmation by the lubricator to the external control system (PLC) for the duration of the motor run (MR).

The motor runtime (MR) depends on various conditions like the counterpressure established or present in the hydraulic system and the temperature. The motor runtime (MR) of the lubricator is 7...17 seconds (MR = 7...17 seconds).

- Ü During the motor run, the green LED lights up on the display; in addition, a numerical value 1...50 is shown on the display which indicates the rough counterpressure in bar.
  - Ü After completion of a faultless and successful motor run (MR), the output signal to the lubricator changes from a low signal to a high signal.
- 
- i Not before >3 seconds after the end of the faultless and successful motor run, the next control signal can be sent by the external control system (PLC). In the meantime, the lubricator does not process any control signals.
  - i To ensure reliable and clear recognition of the control signal, a pause time must be observed. For the 2-second control signal, a pause time (Tp) of at least 22 seconds applies for the lubricator between two identical or different control signals.
  - i If an error is recognized by the integrated microelectronics of the lubricator during or directly after the end of a motor run (MR), this fault is transmitted to the external control system (PLC) by means of a respective output signal (see chapter 7.3 "Output signals / Display messages – external control system (PLC)") and also visualized by means of the appropriate display information with a continuously flashing red LED (see chapter 6.4 "Error messages").

### 7.2.2 3-second control signal

The 3-second control signal triggers two sequential dispensing processes. After a pause time of at least 41 seconds, this control signal can be repeated, or a different control signal can be transmitted.

The lubricator reacts to control signals at PIN 2 only in a specific operating status. The operating conditions are transmitted by the lubricator via PIN 4 as high/low signal and must be picked up and processed accordingly in the PLC.

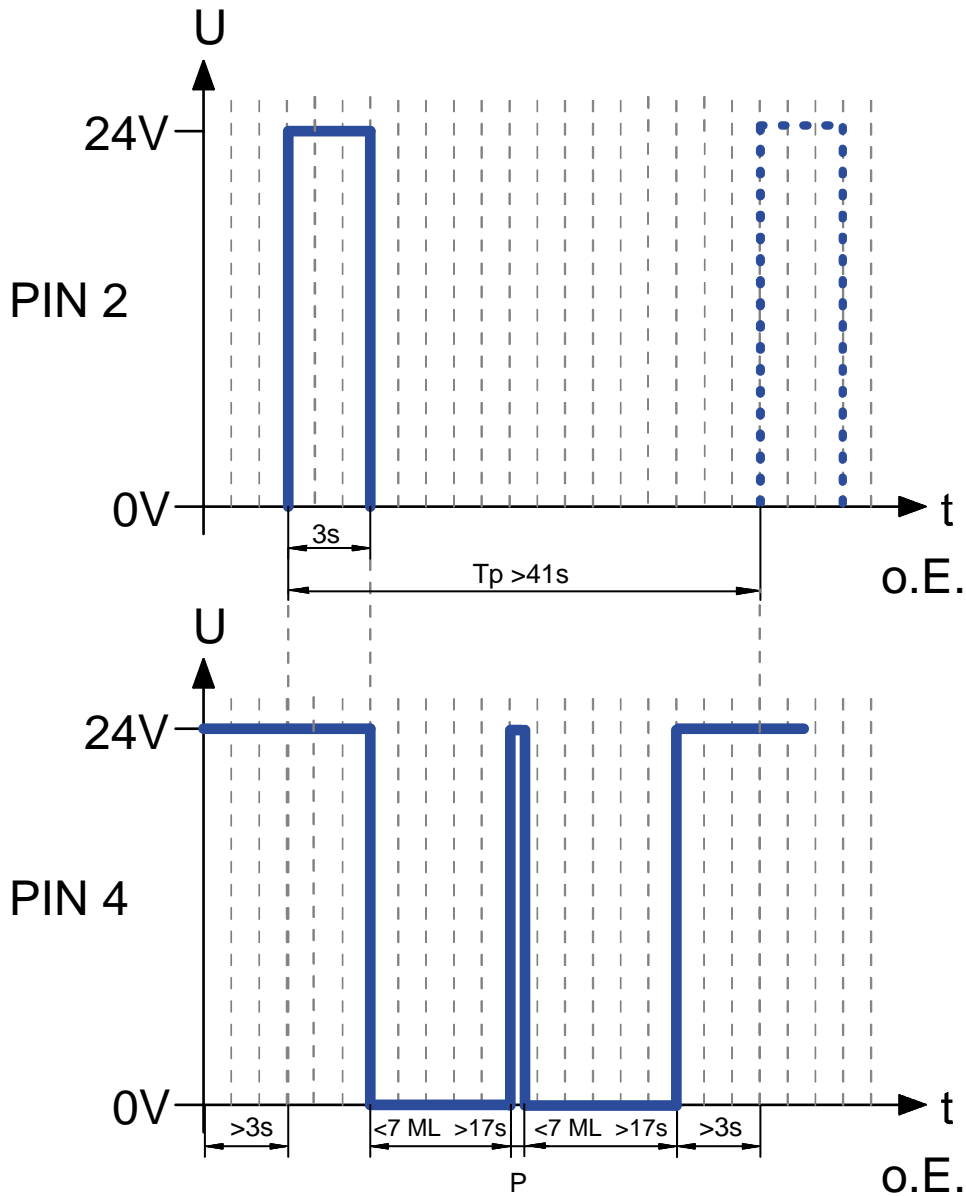

$T_p$ : pause time

MR: motor run

P: Pause between motor runs

**Description:**

- Ü The lubricator is properly connected both to an external control system via the electrical interface and to the voltage supply.
- Ü If impulse mode is activated at the lubricator, *PAU* is shown on the display.
- Ü There are no errors on the lubricator; the lubricator is ready for operation; the green LED on the display flashes once every 5 seconds.

The lubricator sends a permanent output signal (high level) to PIN 4 indicating readiness to the external control system (PLC). This output signal must be active permanently and without interruption for >3 seconds. Activation by an external control system is possible only if this condition is met.

- The 3-second control signal with a signal duration of 3 (2.9 ... 3.1) seconds high signal can be sent to the lubricator from the external control system (PLC).
- Ü While there is a high input signal from the external control system (PLC) at PIN 2 of the lubricator, *PAU* is shown flashing on the display.

Directly after release of the signal the motor run (MR) of the lubricator is started and 0.15 cm<sup>3</sup> of lubricant is conveyed to the outlet. At the same time as the start of motor run (MR), a low output signal is sent for confirmation by the lubricator to the external control system (PLC) for the duration of the motor run (MR).

The motor runtime (MR) depends on various conditions like the counterpressure established or present in the hydraulic system and the temperature. The motor runtime (MR) of the lubricator is 7...17 seconds (MR = 7...17 seconds).

- Ü During the motor run, the green LED lights up on the display; in addition, a numerical value 1...50 is shown on the display which indicates the rough counterpressure in bar.
  - Ü After completion of a faultless and successful motor run (MR), the output signal to the lubricator changes from a low signal to a high signal.
- 
- i Not before >3 seconds after the end of the faultless and successful motor run, the next control signal can be sent by the external control system (PLC). In the meantime, the lubricator does not process any control signals.
  - i To ensure reliable and clear recognition of the control signal, a pause time must be observed. For the 3-second control signal, a pause time (Tp) of at least 41 seconds applies for the lubricator between two identical or different control signals.
  - i If an error is recognized by the integrated microelectronics of the lubricator during or directly after the end of a motor run (MR), this fault is transmitted to the external control system (PLC) by means of a respective output signal (see chapter 7.3 "Output signals / Display messages – external control system (PLC)") and also visualized by means of the appropriate display information with a continuously flashing red LED (see chapter 6.4 "Error messages").



7.2.3 12-second control signal

The 12-second control signal triggers the *FIL* function through the external control system. A total of 40 dispensing processes are automatically executed one after the other. After a specific pause time, this control signal can be repeated, or a different control signal can be transmitted.

The lubricator reacts to control signals at PIN 2 only in a specific operating status. The operating conditions are transmitted by the lubricator via PIN 4 as high/low signal and must be picked up and processed accordingly in the PLC.

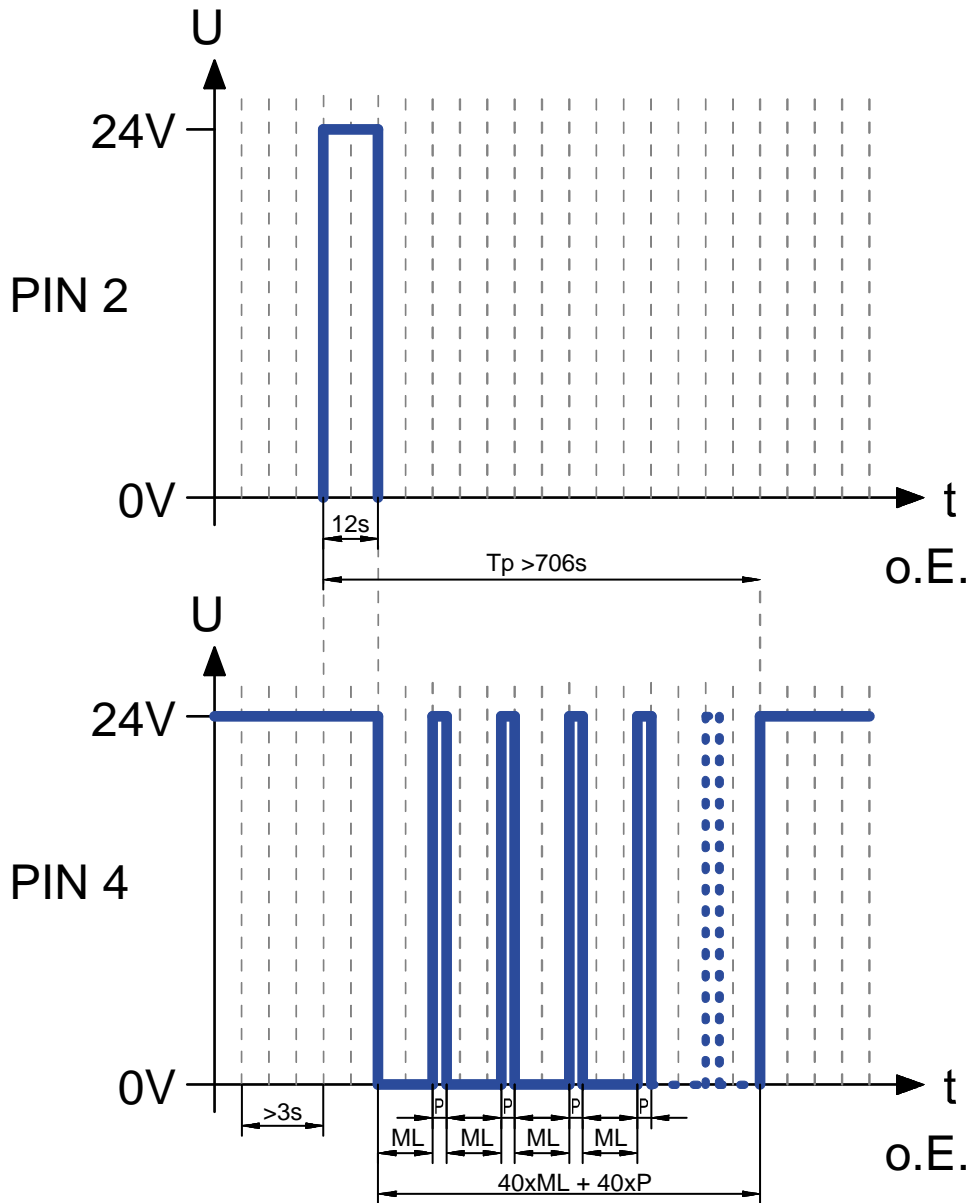

Tp: pause time  
 MR: motor run  
 P: Pause between motor runs

**Description:**

- Ü The lubricator is properly connected both to an external control system via the electrical interface and to the voltage supply.
- Ü If impulse mode *PAU* is activated at the lubricator, *PAU* is shown on the display.
- Ü There are no errors on the lubricator; the lubricator is ready for operation; the green LED on the display flashes rhythmically once every 5 seconds.

The lubricator sends a permanent output signal (high level) to PIN 4 indicating readiness to the external control system (PLC). This output signal must be active permanently and without interruption for >3 seconds. Activation by an external control system is possible only if this condition is met.

- The 12-second control signal with a signal duration of 12 (11.9 ... 12.1) seconds high signal can be sent to the lubricator from the external control system (PLC).
- Ü While there is a high input signal from the external control system (PLC) at PIN 2 of the lubricator, *PAU* is shown flashing on the display.

Directly after release of the signal the first motor run (MR) of the lubricator is started and 0.15 cm<sup>3</sup> of lubricant is conveyed to the outlet. At the same time as the start of motor run (MR), a low output signal is sent for confirmation by the lubricator to the external control system (PLC) for the duration of the motor run (MR).

The motor runtime (MR) depends on various conditions like the counterpressure established or present in the hydraulic system and the temperature. The motor runtime (MR) of the lubricator is 7...17 seconds (MR = 7...17 seconds).

- Ü During each motor run (MR), the green LED lights up on the display; in addition, a numerical value 1...50 is shown on the display which indicates the rough counterpressure in bar.
  - Ü After completion of every faultless and successful motor run (MR), the output signal to the lubricator changes from a low to a high signal for a short pause time of P = 0.5 seconds.
  - Ü This is followed by a total of 40 successive motor runs and dispensing processes. In this process, a lubricant volume of 40 x 0.15 cm<sup>3</sup> = 6.0 cm<sup>3</sup> is conveyed from the cartridge to the outlet.
- i Not before >3 seconds after the end of the last faultless and successful motor run, the next control signal can be sent by the external control system (PLC). In the meantime, the lubricator does not process any control signals.
  - i To ensure reliable and clear recognition of the control signal, a pause time must be observed. For the 12-second control signal, a pause time (Tp) of at least 706 (Tp=MRmaxx40 strokes+Px40 strokes+tolerance) seconds applies for the lubricator between two identical or different control signals.
  - i If an error is recognized by the integrated microelectronics of the lubricator during or directly after the end of a motor run, this fault is transmitted to the external control system (PLC) by means of a respective output signal (see chapter 7.3 "Output signals / Display messages – external control system (PLC)") and also visualized by means of the appropriate display information with a continuously flashing red LED (see chapter 6.4 "Error messages").

**7.2.4 10-second control signal**

The 10-second control signal serves for acknowledgment of error messages of errors *E3* (undervoltage) and *E7* (overload). This is the only control signal that can be processed by the lubricator if a low output signal is sent. Irrespective from the general possibility of remote error acknowledgment, the cause of every error message must be identified and corrected.

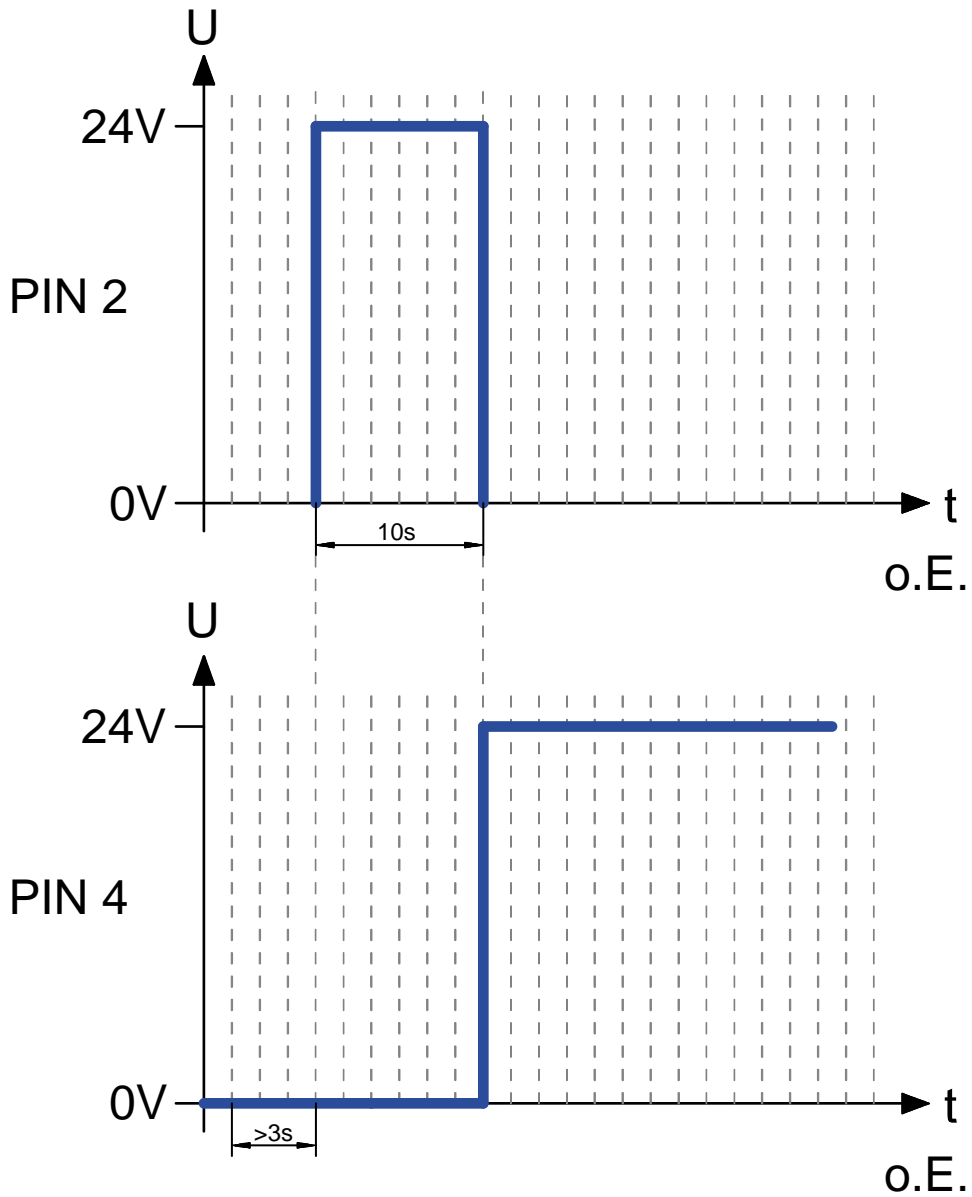

**Description:**

- Ü The lubricator is properly connected both to an external control system via the electrical interface and to the voltage supply.
- Ü If impulse mode is activated at the lubricator, *PAU* is shown on the display.
- Ü *Error E3* or *E7* is active on the lubricator.

The lubricator sends a permanent output signal (low signal) to PIN 4 indicating an error to the external control system (PLC). This output signal must be active permanently and without interruption for >3 seconds.

- The control signal with a signal duration of 10 (9.9 ... 10.1) seconds high signal can be sent to the lubricator from the external control system (PLC).

Ü After the control signal, the following independent checks are carried out by the integrated microelectronics of the lubricator:

If the internal checks are successful:

The output signal at the lubricator changes from a low signal to a high signal, error *E3* or *E7* is thus acknowledged and the lubricator is ready again. In the display, *Clr* is shown briefly, then *PAU* is shown again.

If the internal checks are **not** successful:

The lubricator continues to send a low output signal. The error still applies. On the display, the error is still shown, the red LED continues to flash permanently. For further measures in this case, see chapter 6.4 "Error messages".

- i Not before >3 seconds after the high output signal is active again at PIN 4, the control signal can be sent by the external control system (PLC). In the meantime, the lubricator does not process any control signals!
- i Irrespective of the general possibility of remote error acknowledgment, the cause of every error message must be identified and corrected (see chapter 6.4 "Error messages").

**7.3 Output signals / Display messages – external control system (PLC)**

Display	Designation	Output signal (PIN 4)	See chapter
OFF	Switched off	Low, permanent	6.2
PAU	Ready	High, permanent	7
PAU flashing	Control signal received	High, permanent	7
01...50	Dispensing	Low, 10...18 seconds	7
E1	Empty cartridge	0.5Hz square-wave signal, permanent	7.3.1
E2	Cartridge error	Low, permanent	7.3.2
E3	Undervoltage	Low, permanent	7.3.3
E4/E5	Fatal error	Low, permanent	7.3.4
E7	Overload/overpressure	Low, permanent	7.3.5

Tbl - 12 Display messages

### 7.3.1 Error *E1* (empty cartridge) – external control system (PLC)

The integrated microelectronics of the lubricator is equipped with an automatic counter, which counts the number of delivery operations after fitting a new and full cartridge. For a cartridge with 125 cm<sup>3</sup> of lubricant, the number of strokes is 780; for a cartridge with 250 cm<sup>3</sup> of lubricant, the number of strokes is 1560. The low calculative difference serves as protection against the ingress of air into the hydraulic system. This ensures that the empty cartridge message (error *E1*) is sent to the external control system (PLC) on time. For this, a dedicated and unique output signal can be easily, quickly and reliably recognized by the external control system (PLC).

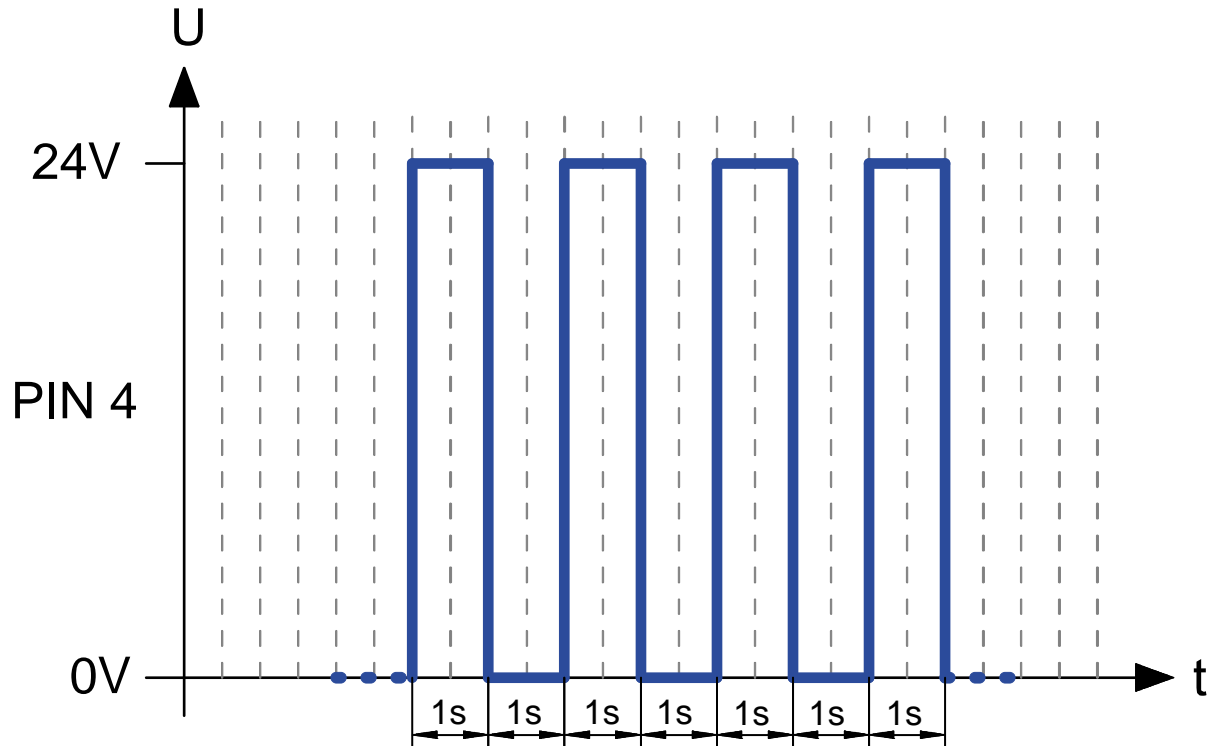

#### Description:

- Ü The lubricator is properly connected both to an external control system via the electrical interface and to the voltage supply.
- Ü If impulse mode *PAU* is activated at the lubricator, *E1* is shown on the display and the red LED lights up.

The error *E1* (empty signal) can only occur directly after dispensing.

The error *E1* (empty signal) does not need to be acknowledged, and cannot be acknowledged. Troubleshooting measures are described in chapter 8.1.3 "Cartridge change".

- After removing the cartridge with the lubricator switched on, the lubricator sends a permanent low output signal (0 V) to PIN 4 (error *E2*).
- i Until all errors are corrected, the lubricator does not process any control signals.

The transfer of the output signals when changing a cartridge at the enabled lubricator is illustrated and described below:

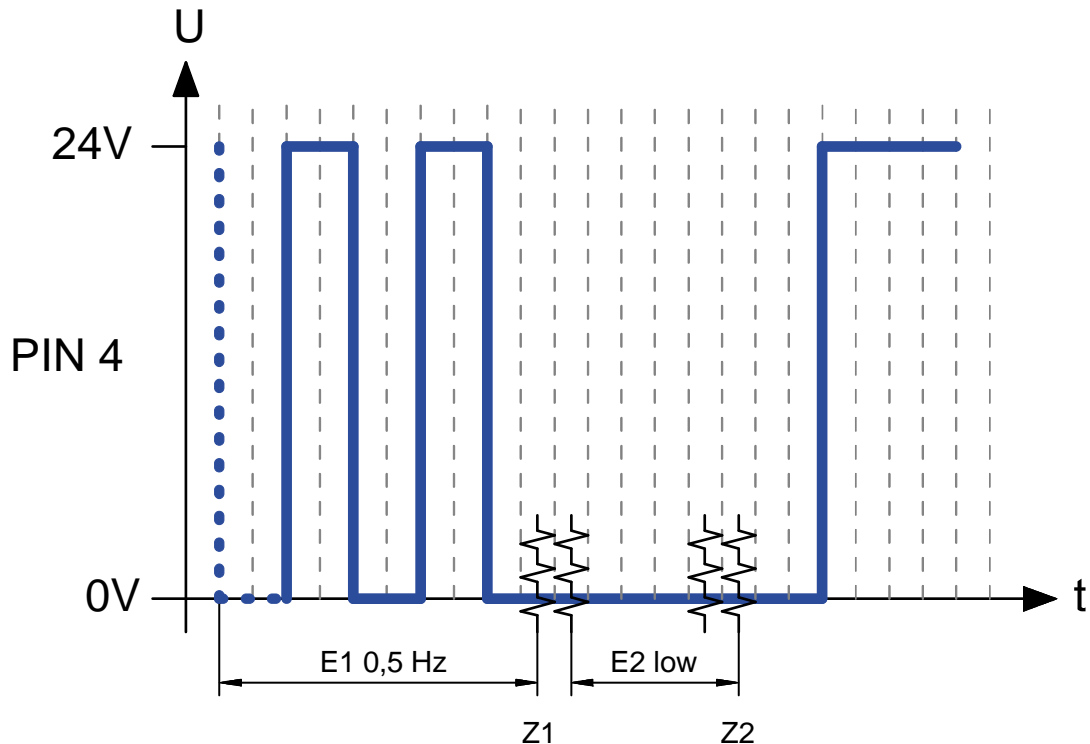

Z1: Removal of empty cartridge

Z2: Opening the new cartridge

**Description:**

- Ü The lubricator is properly connected both to an external control system via the electrical interface and to the voltage supply.
- Ü If impulse mode *PAU* is activated at the lubricator, *E1* is shown on the display and the red LED lights up.

The empty cartridge occurred after dispensing, the output signal of the lubricator is the 0.5Hz square-wave signal (empty signal) (0/+24V).

**Z1** indicates the time of removal of the empty cartridge. The output signal of the lubricator now changes from a 0.5 Hz square-wave signal to a permanent low signal (0V) and indicates a cartridge error (see chapter 7.3.2 "Error E2 (cartridge error) – external control system (PLC)").

**Z2** indicates the time a new full cartridge is connected. The output signal of the lubricator now changes from the permanent low signal (0V) to a permanent high signal (+24V). This way, the lubricator signals to the external control system (PLC) that it is ready again.

If the empty cartridge signal has occurred during execution of the 12-seconds control signal, the remaining strokes are executed after attachment of the new cartridge.

- i Until all errors are corrected, the lubricator does not process any control signals.

### 7.3.2 Error *E2* (cartridge error) – external control system (PLC)

The error *E2* (cartridge error) indicates that no cartridge is connected to the lubricator. The cartridge sensor integrated onto the top of the lubricator recognizes when a cartridge is connected to the lubricator properly; the capacity or lubricant type in the cartridge is not identified in this process.

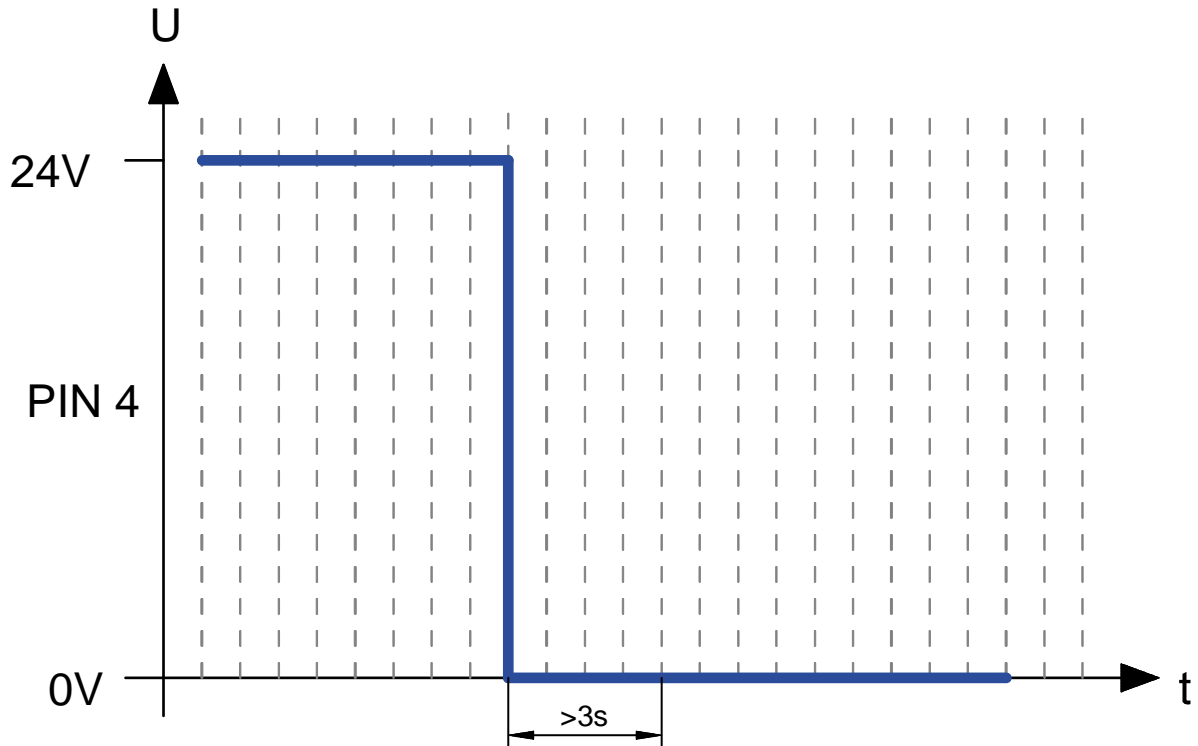

#### Description:

- Ü The lubricator is properly connected both to an external control system via the electrical interface and to the voltage supply.
- Ü If impulse mode *PAU* is activated at the lubricator, *E2* is shown on the display and the red LED lights up.

The error *E2* (cartridge error) does not need to be acknowledged, and cannot be acknowledged. Troubleshooting measures are described in chapter 8.1.3 "Cartridge change".

The error *E2* (cartridge error) interrupts ongoing dispensing processes at the lubricator.

- Until a cartridge is properly connected with the lubricator switched on, the lubricator sends a permanent low output signal (0 V) to PIN 4.
- i Until all errors are corrected, the lubricator does not process any control signals.

	NOTICE
	<p><b>Already opened lubricant cartridges must not be reattached to the lubricator, as the integrated stroke counter is automatically reset after a cartridge is removed.</b></p> <ul style="list-style-type: none"> <li>· Always use full lubricant cartridges.</li> </ul>

**7.3.3 Error E3 (undervoltage) – external control system (PLC)**

The error *E3* (undervoltage) indicates that the voltage supply of the lubricator is not within the required parameters.

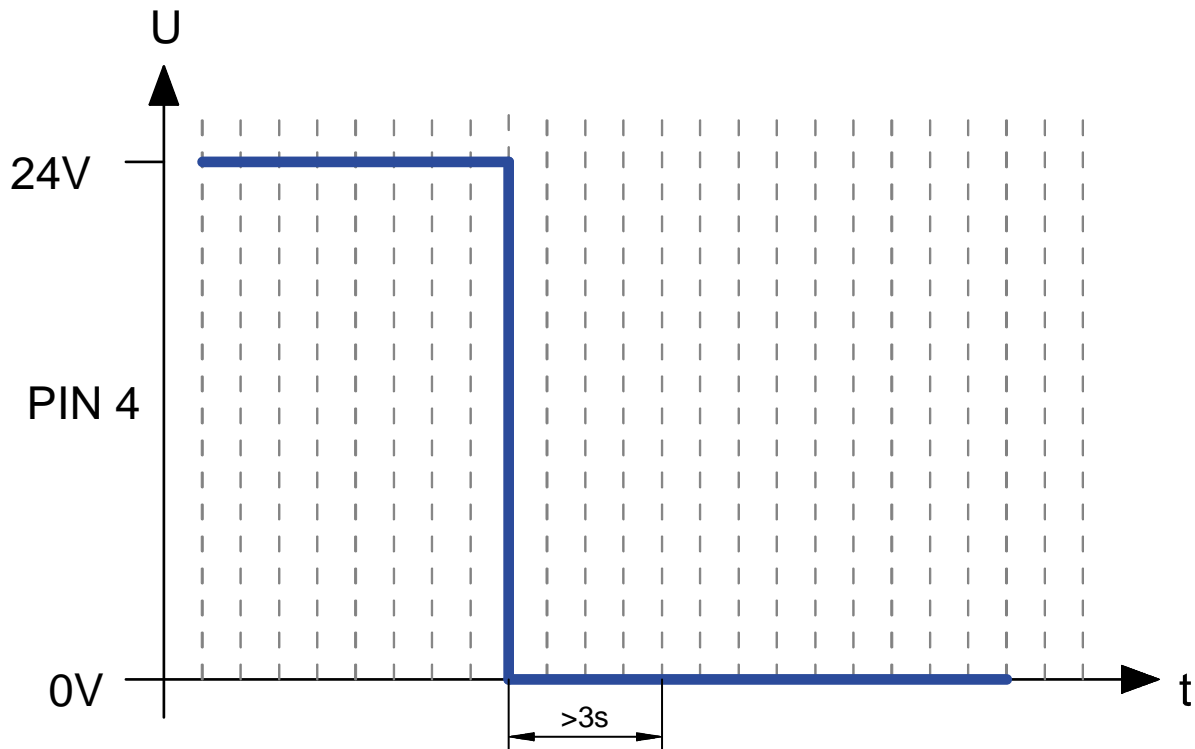
**Description:**

- Ü The lubricator is properly connected both to an external control system via the electrical interface and to the voltage supply.
- Ü If impulse mode *PAU* is activated at the lubricator, *E3* is shown on the display and the red LED lights up.

If the supply voltage is too low, the lubricator sends a permanent low output signal (0V) at PIN 4 to the external control system (PLC).

- The error *E3* (undervoltage) must be acknowledged with the 10-second control signal (see chapter 7.2.4 "10-second control signal") once the cause or causes have been corrected.
- i Until all errors are corrected, the lubricator does not process any control signals.



### 7.3.4 Error $E4/E5$ (fatal error) – external control system (PLC)

The error  $E4/E5$  (fatal error) indicates that the integrated microelectronics have recognized a fatal error and that the lubricator is not working within the permissible parameters. This may be caused by mechanical, electronic or other defects.

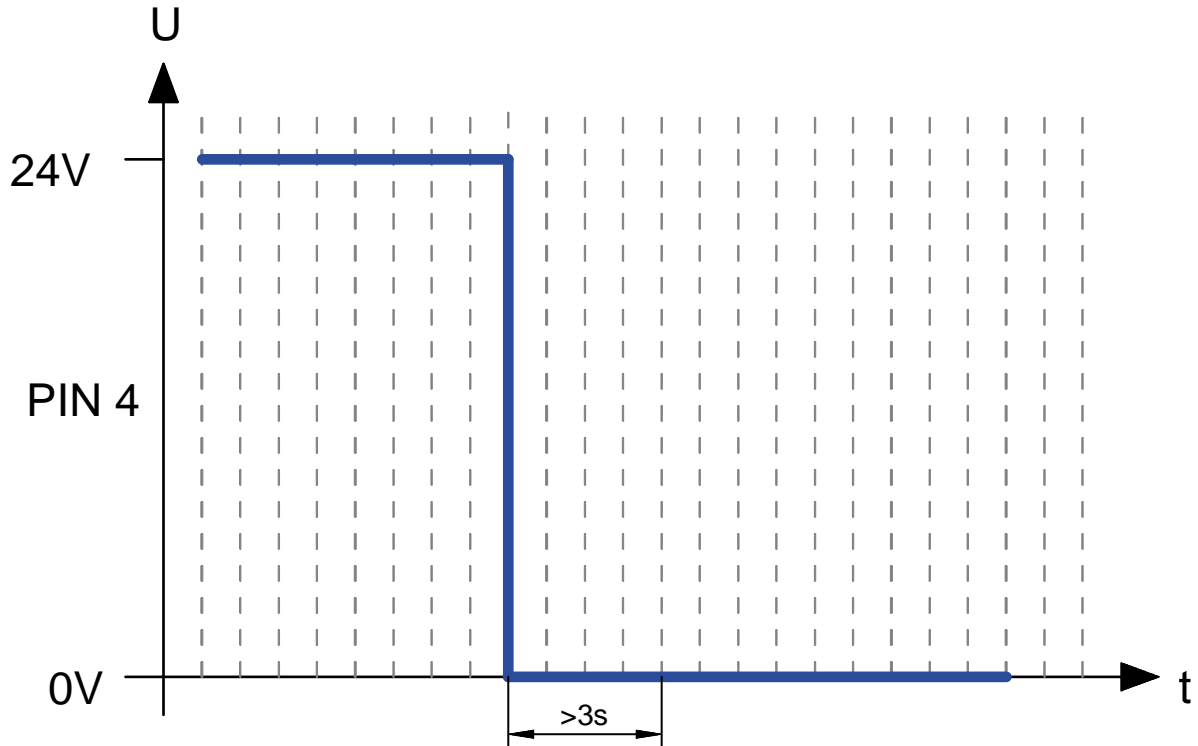

#### Description:

- Ü The lubricator is properly connected both to an external control system via the electrical interface and to the voltage supply.
- Ü If impulse mode  $PAU$  is activated at the lubricator,  $E4/E5$  is shown on the display and the red LED lights up.

The (fatal) error  $E4/E5$  was recognized during (internal) diagnosis.

The error  $E4/E5$  can have different causes:

- Increased voltage for a short time, 28...30 V, and therefore the motor runtime is too short.
- The connected supply voltage was too low and the motor runtime too long.
- In these cases, the error is corrected by switching the power supply off and on again.

**Important!** Between switching the lubricator off and on, 60 seconds must elapse. If the error  $E4/E5$  still persists, remove the lubricator from the application and return it with the lubricant cartridge and a description of the error to **WITTENSTEIN alpha GmbH**.

- i Do not open the lubricator without permission! Observe the applicable information and regulations for intended use (see chapter 2.3 "Intended use") and guarantee (see chapter 2.5 "Guarantee and liability")!

### 7.3.5 Error *E7* (overload) – external control system (PLC)

During dispensing, the error *E7* (overload) indicates a hydraulic overload, i.e. if the maximum pressure is exceeded.

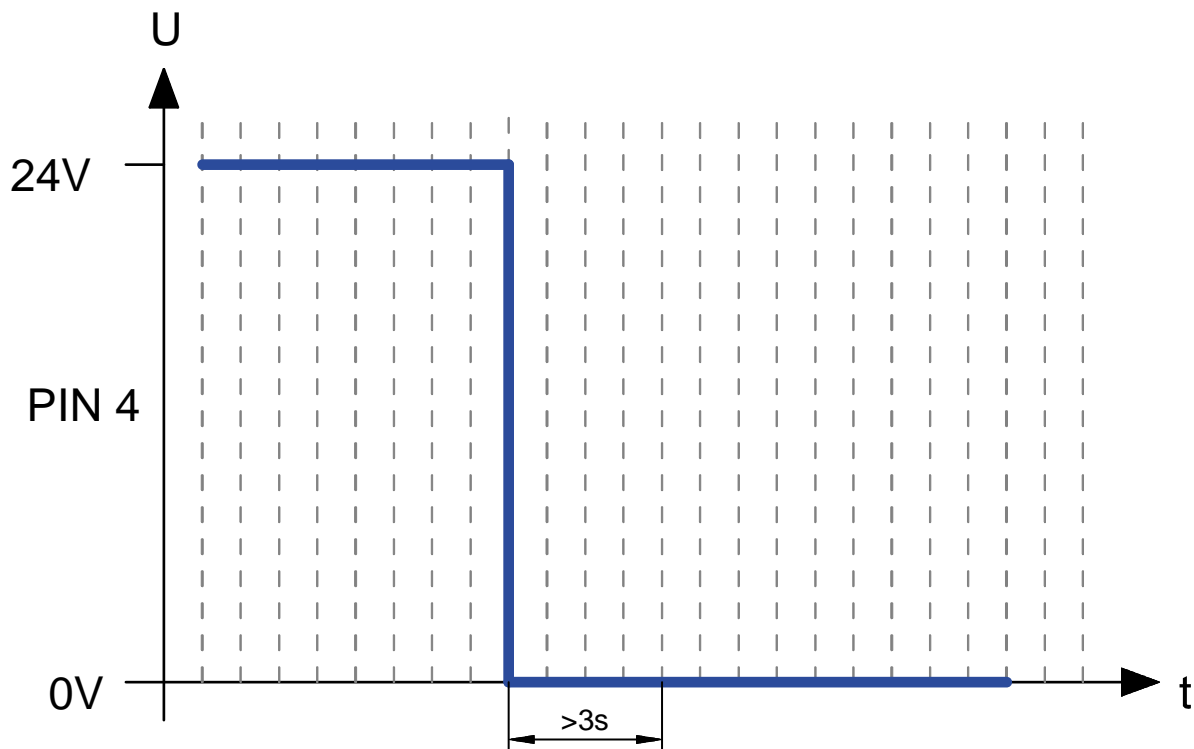

#### Description:

- Ü The lubricator is properly connected both to an external control system via the electrical interface and to the voltage supply.
- Ü Directly before the *E7* error occurs, the lubricator was successfully activated by the external control system (PLC) and has attempted to execute / executed dispensing.

If impulse mode *PAU* is activated at the lubricator, *E7* is shown on the display and the red LED lights up.

The error *E7* can have different causes:

- Lubrication point clogged/blocked
- Hose bent (observe the maximum allowable bend radius).
- Hose too long.
- Accessories not connected properly.

When the maximum admissible pressure is reached during/after dispensing, the lubricator sends a permanent low output signal (0V) at PIN 4 to the external control system (PLC).

The error *E7* (overload) must be acknowledged with the 10-second control signal (see chapter 7.3.2 "Error *E2* (cartridge error) – external control system (PLC)") once the cause or causes have been corrected.

- i Until all errors are corrected, the lubricator does not process any control signals.

## 8 Maintenance and disposal

- Before carrying out any maintenance or work, please note the general safety instructions (see chapter 2 "Safety") and observe all applicable local and operational safety regulations.
- Do not disable any protective device without authorization!

### 8.1 Maintenance schedule

The following maintenance schedule for the lubricator must be observed:

Maintenance	Commissioning	After 500 hours or after 3 months	Annually	If necessary
Visual inspection	X	X	X	X*
Cleaning	X	X	X	X*
Cartridge change	X**		X***	X*
* Depending on application conditions and lubricant consumption ** Depending on the delivery condition (ordered version) *** Recommended after 2 years at the latest				

Tbl - 13 Maintenance schedule.

#### 8.1.1 Visual inspection

- Check the entire lubrication system (lubricator and any connected accessories including cords, hoses and distributors) by careful visual inspection for external damage (e.g. loose connections).
- Check the condition of the lubrication point for correct lubricant supply.
- Replace damaged or defective parts immediately to ensure a continuous and permanent lubrication.
- Check the fill level in the cartridge on the lubricator.
- Check any error messages at the lubricator and correct the causes respectively.

#### 8.1.2 Cleaning

- Clean the lubricator by suitable means (e.g. absorbent cloths) to remove dirt.

	NOTICE
	<p><b>Among other things, compressed air can lead to damage to the seals of the lubricator and to contamination of the lubricator or lubricant by dirt and particles.</b></p> <ul style="list-style-type: none"> <li>· Do not use compressed air for cleaning the lubricator.</li> </ul>

### 8.1.3 Cartridge change

	NOTICE
	<p><b>Already opened lubricant cartridges must not be reattached to the lubricator, as the integrated stroke counter is automatically reset after a cartridge is removed.</b></p> <ul style="list-style-type: none"> <li>· Always use full lubricant cartridges.</li> </ul>
	<p><b>Only use original lubricant cartridges with lubricants approved by WITTENSTEIN alpha GmbH.</b></p> <ul style="list-style-type: none"> <li>· Observe the maximum storage time of lubricants filled in cartridges.</li> </ul>
	<p><b>Refilling of empty or open lubricant cartridges is not possible.</b></p> <p><b>Make sure that the same lubricant is used in the new cartridge as already used before. Make sure that only cartridges with the same capacity are used.</b></p> <ul style="list-style-type: none"> <li>· Compare the specifications on the lubricant cartridge.</li> </ul>

The following table indicates the available lubricant cartridges:

Designation	Lubricant	Capacity	Material number
LUE+125-05-1	WITTENSTEIN alpha G11	125 cm <sup>3</sup>	20068231
LUE+125-06-1	WITTENSTEIN alpha G12	125 cm <sup>3</sup>	20068233
LUE+125-07-1	WITTENSTEIN alpha G13	125 cm <sup>3</sup>	20068236
LUE+125-00-1	Klüber Microlube GB0	125 cm <sup>3</sup>	20068238

Tbl - 14 Exchange cartridges.

Changing lubricant cartridges at the lubricator is easy and only requires two steps.

The cartridge only needs to be changed if it is empty or if the useful life of the lubricant was exceeded. Cartridges can be changed during normal operation of the lubricator. Besides changing the cartridge, no additional measures are necessary!

Ü A malfunction has occurred at the lubricator (error *E1*); the red LED flashes every 5 seconds to visually indicate an error.

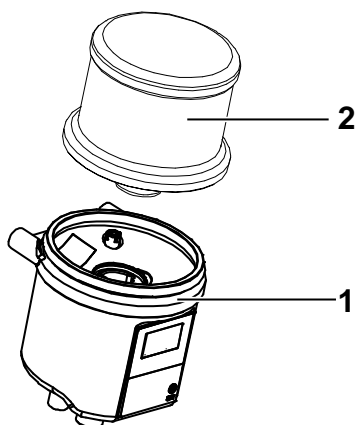

#### Unscrew the empty cartridge of the lubricator.

- Turn the empty cartridge [2] counter-clockwise to remove it from the lubricator [1] and dispose of it in compliance with applicable regulations.
- i Ensure that the work is carried out under clean conditions. Dirt and particles must not enter the lubricant inlet. If necessary, clean before you start working (chapter 8.1.2 "Cleaning").

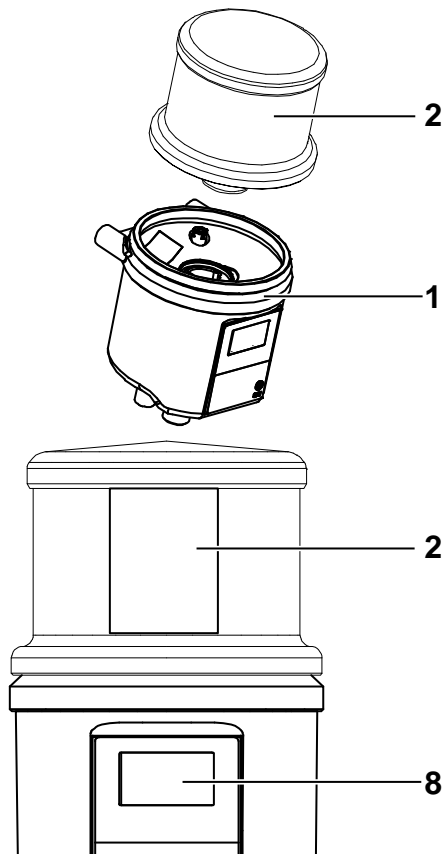

### Connection of the new lubricant cartridge

- Set the full lubricant cartridge [2] on the lubricator [1].
  - Turn the lubricant cartridge clockwise to tighten it to the lubricator.
- i The final position is reached after two full turns when the label of the lubricant cartridge [2] is aligned flush with the front cover [8] of the lubricator.

- Ü If error *E1* was shown on the display before the cartridge was changed, the display expires and the red LED flashes every 5 seconds. Separate acknowledgment is not required. The green LED flashes briefly every 5 seconds.
- Ü After completion, the lubricator automatically returns to the last active mode (*PAU* or *OFF*).
- i If the empty cartridge (error *E1*) occurred during a dispensing cycle (delivery), it is automatically interrupted and continued after the work is completed.

## 8.2 Recommissioning

- Reinstall all safeguards and make sure that all tools have been removed from the hazard area.
- Make sure that the lubricator is activated.

## 8.3 Disposal

- For disposal of the lubricator as well as any empty or opened cartridges, applicable national regulations must be observed.
  - For disposal, the respective safety data sheets and disposal instructions for the individual components must be observed.
- i Refilling of empty lubricant cartridges is not possible.

## 9 Appendix

### 9.1 EC/EU declaration of conformity



#### Declaration of EG conformity

According to the Machinery Directive 2006/42/EG of 2006, May 17th



Herewith the manufacturer  
DLS Schmiersysteme GmbH; Gewerbering 5; D-82140 Olching  
Declare that the following lubricating system

#### FlexxPump 125 (24V DC)

Delivered by us, concerning design and construction as well as the model put into circulation, comply with the EG directives 2006/42/EG. In particular, the following harmonized standards were applied:

EN 12100:2011-03 Safety of machinery

#### According to the EG directive on Electromagnetic Compatibility 2014/30/EU

The manufacturer herewith declares that the following lubrication system

#### FlexxPump 125 (24V DC)

Delivered by us, concerning design and construction as well as the model put into circulation, comply with the above-mentioned EU directive. In particular, the following harmonized standards were applied:

EN 61000-6-2, EN 61000-6-4 Electromagnetic Compatibility (EMC)

Authorized representative for the compilation of technical documentation:

Reiner Hochholzer  
Geschäftsführer  
DLS Schmiersysteme GmbH  
Gewerbering 5  
D-82140 Olching

Olching, 18.02.2020



Reiner Hochholzer; Geschäftsführer

DLS Schmiersysteme GmbH  
Gewerbering 5  
D-82140 Olching  
+49 8142 650 690  
+49 8142 650 6929  
www.dls-schmiersysteme.de

## Revision history

Revision	Date	Comment	Chapter
01	03/17/2022	New version	All



alpha

WITTENSTEIN alpha GmbH · Walter-Wittenstein-Straße 1 · 97999 Igersheim · Germany  
Tel. +49 7931 493-12900 · [info@wittenstein.de](mailto:info@wittenstein.de)

**WITTENSTEIN – one with the future**  
**[www.wittenstein-alpha.de](http://www.wittenstein-alpha.de)**