

Rotary systems with straight tootinging

Know-how of linear technology for rotary applications

Applications for gearboxes with a straight-toothed output pinion can be found where smooth operation has a low priority, axial forces generated by helical teeth should be prevented, or a straight-toothed mating gear such as a gear ring is already chosen. We now offer an extensive portfolio for such applications. Depending on the requirements regarding positioning accuracy and feed force one can choose between a variety

of alternative solutions. You can create the perfect drive configuration quickly and easily using the new "gear ring" module in cymex®. Drives with a straight-toothed output pinion are not only suitable for gear rings, they can also be used in combination with straight-toothed racks.

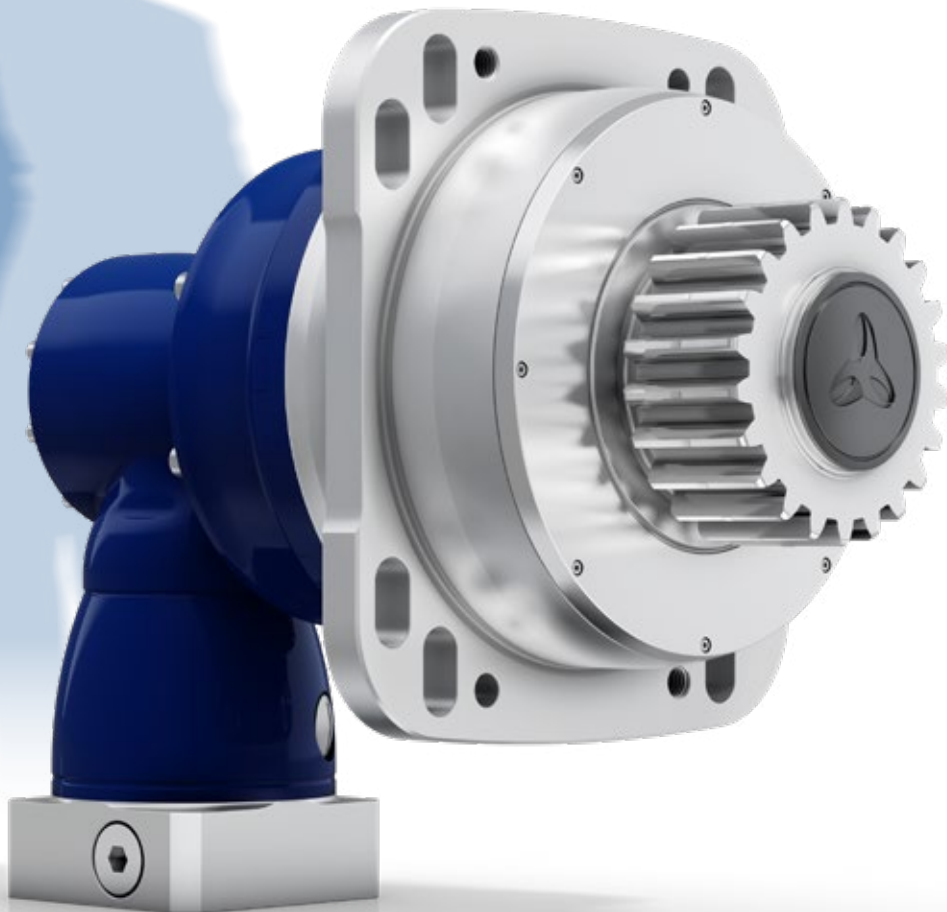
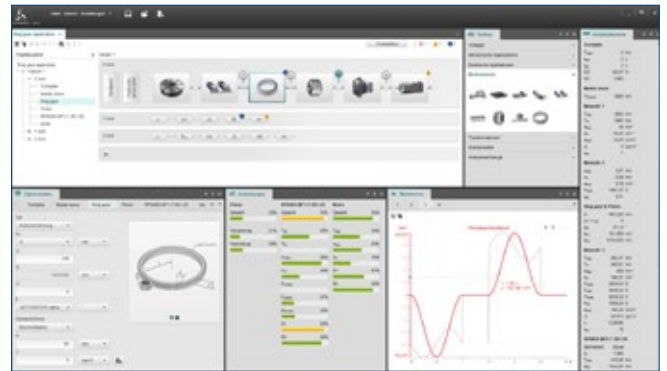

RPK+ with straight-toothed output pinion

Bed-type milling machine

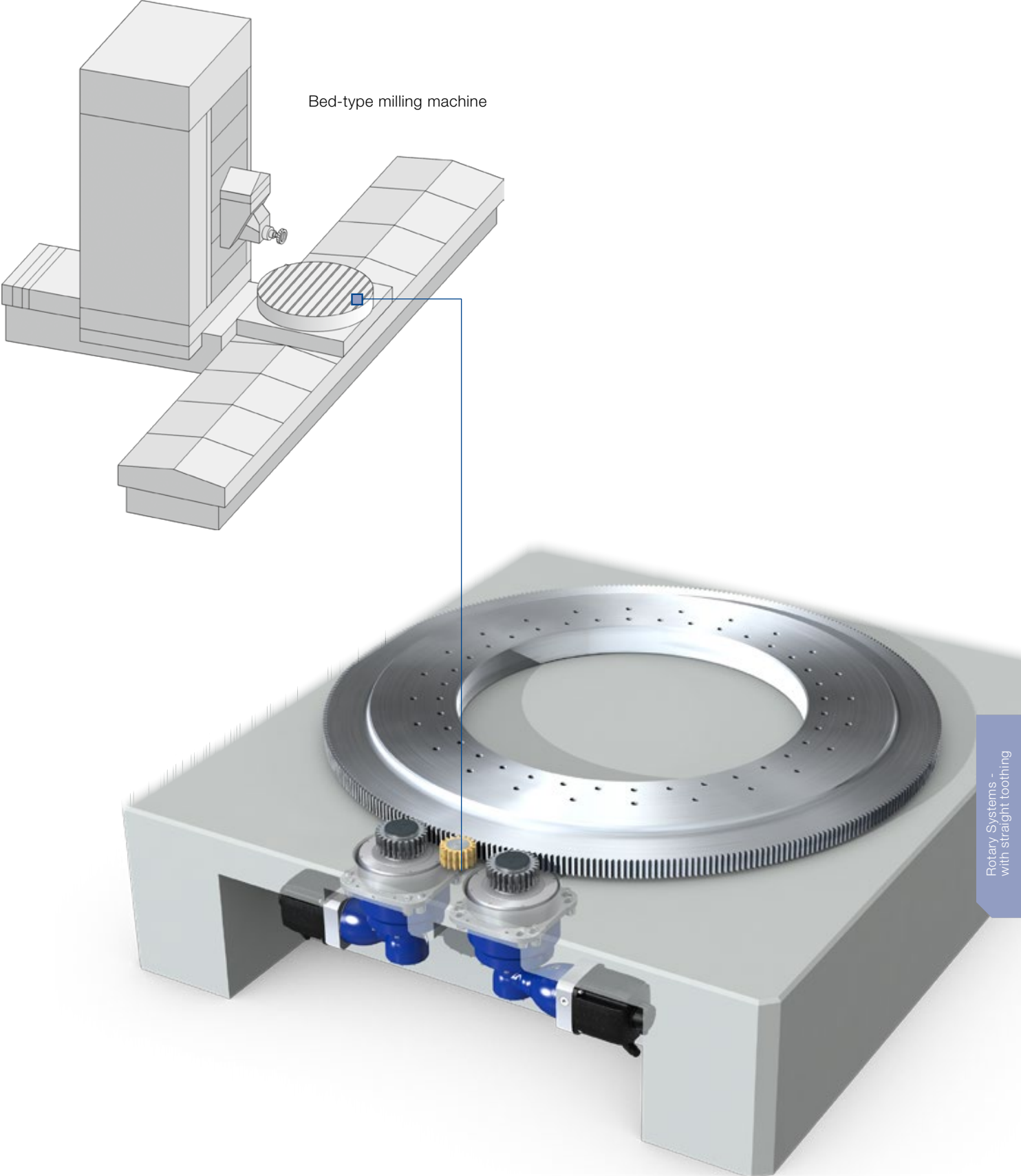

Rotary systems with straight tothing – Value Segment

NPR, NPS and NPL with straight-toothed RMK preferred pinion

Pinion	NPR / NPS / NPL				Set consisting of lubrication pinion and axis ¹⁾
	015	025	035	045	
Ordering code	F_{2T}^* [N]	F_{2T}^* [N]	F_{2T}^* [N]	F_{2T}^* [N]	Ordering code
RMK 150-222-20G0-016-022	1990				LMT 150-PU -24G0-020-1
RMK 200-222-19G0-016-019	2100				LMT 200-PU -17G0-020-1
RMK 200-222-22G0-022-020		3400			LMT 200-PU -17G0-020-1
RMK 300-222-22G0-032-019			6170		LMT 300-PU -17G0-030-1
RMK 300-222-25G0-040-036				9300	LMT 300-PU -17G0-030-1
RMK 400-222-20G0-040-036				9300	LMT 400-PU -17G0-040-1

* F_{2T} Tangential force / feed force – adhere to the permissible tangential force of mating gear

¹⁾ See page 118 for further information on the lubricator and lubrication system
Application-specific dimensioning with cymex® – www.wittenstein-cymex.com

NP with straight-toothed RMK preferred pinion

Pinion	NP				Set consisting of lubrication pinion and axis ¹⁾
	015	025	035	045	
Ordering code	F_{2T}^* [N]	F_{2T}^* [N]	F_{2T}^* [N]	F_{2T}^* [N]	Ordering code
RMK 150-222-20G0-016-022	1160				LMT 150-PU -24G0-020-1
RMK 200-222-19G0-016-019	2100				LMT 200-PU -17G0-020-1
RMK 200-222-22G0-022-020		2020			LMT 200-PU -17G0-020-1
RMK 300-222-22G0-032-019			4680		LMT 300-PU -17G0-030-1
RMK 300-222-25G0-040-036				7450	LMT 300-PU -17G0-030-1
RMK 400-222-20G0-040-036				7450	LMT 400-PU -17G0-040-1

* F_{2T} Tangential force / feed force – adhere to the permissible tangential force of mating gear

¹⁾ See page 118 for further information on the lubricator and lubrication system
Application-specific dimensioning with cymex® – www.wittenstein-cymex.com

Pinion designation	Gearbox size	m [mm]	z []	x []	d [mm]	d_a [mm]	$A \pm 0.3$ [mm]	b [mm]	B [mm]	L_{12} [mm]	L_{13} [mm]	L_{15} [mm]	L_{16} [mm]	L_{17} [mm]	l_{Fq} [mm]
RMK 150-222-20G0-016-022	NPR 015S*	1.5	20	0.3	30	33.9	32.95	21	19	54	41.5	12	32	2	21.5
RMK 200-222-19G0-016-019	NPR 015S*	2	19	0.4	38	43.6	41.8	26	24	54	39	7	27	2	19
RMK 200-222-22G0-022-020	NPR 025S*	2	22	0	44	48	44	26	24	62	40	8	28	9	20
RMK 300-222-22G0-032-019	NPR 035S*	3	22	0	66	71.9	59	31	29	95.5	48.5	4	34	31.5	18.5
RMK 300-222-25G0-040-036	NPR 045S*	3	25	0	75	80.9	63.5	31	29	122	65.5	21	51	41	35.5
RMK 400-222-20G0-040-036	NPR 045S*	4	20	0	80	87.9	75	41	39	122	65.5	16	46	36	35.5

* also applies to NPS

m = Module

z = Number of teeth

d = Pitch circle diameter

x = Addendum modification coefficient

d_a = Tip diameter

Refer to the respective gearbox catalog for the exact gearbox dimensions.

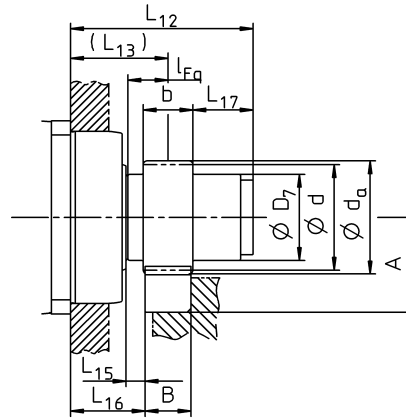

Pinion designation	Gearbox size	m [mm]	z []	x []	d [mm]	d_a [mm]	$A \pm 0.3$ [mm]	b [mm]	B [mm]	L_{12} [mm]	L_{13} [mm]	L_{15} [mm]	L_{16} [mm]	L_{17} [mm]	l_{Fq} [mm]
RMK 150-222-20G0-016-022	NP 015S	1.5	20	0.3	30	33.9	32.95	21	19	42	29.5	12	20	2	21.5
RMK 200-222-19G0-016-019	NP 015S	2	19	0.4	38	43.6	41.8	26	24	42	27	7	15	2	19
RMK 200-222-22G0-022-020	NP 025S	2	22	0	44	48	44	26	24	52	30	8	18	9	20
RMK 300-222-22G0-032-019	NP 035S	3	22	0	66	71.9	59	31	29	77.5	30.5	4	16	31.5	18.5
RMK 300-222-25G0-040-036	NP 045S	3	25	0	75	80.9	63.5	31	29	107	50.5	21	36	41	35.5
RMK 400-222-20G0-040-036	NP 045S	4	20	0	80	87.9	75	41	39	107	50.5	16	31	36	35.5

m = Module

z = Number of teeth

d = Pitch circle diameter

x = Profile correction factor

d_a = Tip diameter

Refer to the respective gearbox catalog for the exact gearbox dimensions.

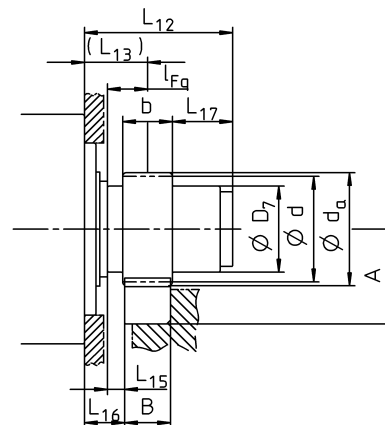

Rotary systems with straight toothing – Advanced Segment

SP⁺, SK⁺, SPK⁺ and SPC⁺ with straight-toothed RMS preferred pinion

Pinion	SP ⁺ / SK ⁺ / SPK ⁺ / SPC ⁺					Set consisting of lubrication pinion and axis ¹⁾
	060 ²⁾	075	100	140	180	
Ordering code	F_{2T}^* [N]	F_{2T}^* [N]	F_{2T}^* [N]	F_{2T}^* [N]	F_{2T}^* [N]	Ordering code
RMS 200-323-16G0-016	2320					LMT 200-PU -17G0-020-1
RMS 200-323-19G0-022		3410				LMT 200-PU -17G0-020-1
RMS 300-323-17G0-032			6170			LMT 300-PU -17G0-030-1
RMS 300-323-22G0-040				9040		LMT 300-PU -17G0-030-1
RMS 400-323-19G0-040				9260		LMT 400-PU -17G0-040-1
RMS 400-323-22G0-055					13300	LMT 400-PU -17G0-040-1
RMS 500-323-19G0-055					13900	LMT 500-PU -17G0-050-1

* F_{2T} Tangential force / feed force – adhere to the permissible tangential force of mating gear

¹⁾ See page 118 for further information on the lubricator and lubrication system

²⁾ not with SPK⁺

Also available with V-Drive VT⁺

Application-specific dimensioning with cymex® – www.wittenstein-cymex.com

TP⁺, TK⁺, TPK⁺ and TPC⁺ with straight-toothed RMF preferred pinion

Pinion	TP ⁺ / TK ⁺ / TPK ⁺ / TPC ⁺					Set consisting of lubrication pinion and axis ¹⁾
	010	025	050	110	TP ⁺ 4000 HIGH TORQUE	
Ordering code	F_{2T}^* [N]	F_{2T}^* [N]	F_{2T}^* [N]	F_{2T}^* [N]	F_{2T}^* [N]	Ordering code
RMF 200-443-36G0-050-8xM6	2640					LMT 200-PU -17G0-020-1
RMF 200-443-36G0-063-12xM6		3500				LMT 200-PU -17G0-020-1
RMF 300-443-37G0-080-12xM8			11500			LMT 300-PU -17G0-030-1
RMF 400-443-40G0-125-12xM10				22400		LMT 400-PU -17G0-040-1
RMF 1000-443-36G0-260-16xM30					176000	LMT 1000-PU -17G0-100-1

* F_{2T} Tangential force / feed force – adhere to the permissible tangential force of mating gear

¹⁾ See page 118 for further information on the lubricator and lubrication system

Also available with V-Drive VT⁺

Application-specific dimensioning with cymex® – www.wittenstein-cymex.com

Pinion designation	Gearbox size	m [mm]	z []	x []	d [mm]	d_a [mm]	$A \pm 0.3$ [mm]	b [mm]	B [mm]	L_{12} [mm]	L_{13} [mm]	L_{15} [mm]	L_{16} [mm]	l_{Fq} [mm]
RMS 200-323-16G0-016	SP 060R*	2	16	0.5	32	38.3	39	26	24	52	39	7	27	19
RMS 200-323-19G0-022	SP 075R*	2	19	0.4	38	43.9	41.8	26	24	53	40	8	28	20
RMS 300-323-17G0-032	SP 100R*	3	17	0.4	51	59.6	52.7	31	29	64	48.5	4	34	18.5
RMS 300-323-22G0-040	SP 140R*	3	22	0.2	66	73.4	59.6	31	29	81	65.5	21	51	35.5
RMS 400-323-19G0-040	SP 140R*	4	19	0.3	76	86.6	74.2	41	39	81	60.5	11	41	30.5
RMS 400-323-22G0-055	SP 180S*	4	22	0.2	88	97.8	79.8	41	39	84	63.5	14	44	33.5
RMS 500-323-19G0-055	SP 180S*	5	19	0.4	95	109.2	83.5	51	49	84	58.5	4	34	28.5

* also applies to SK*, SPK*, SPC*

m = Module

z = Number of teeth

d = Pitch circle diameter

x = Profile correction factor

d_a = Tip diameter

Refer to the respective gearbox catalog for the exact gearbox dimensions.

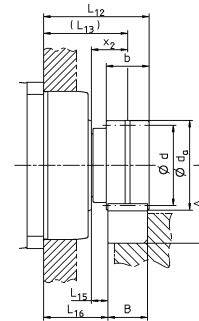

Pinion designation	Gearbox size	m [mm]	z []	x []	d [mm]	d_a [mm]	$A \pm 0.3$ [mm]	b [mm]	B [mm]	L_{12} [mm]	L_{13} [mm]	L_{15} [mm]	L_{16} [mm]	l_{Fq} [mm]
RMF 200-443-36G0-050-8xM6	TP 010S-MF*	2	36	0	72	76.2	48	26	24	56	43	1	31	13
RMF 200-443-36G0-063-12xM6	TP 025S-MF*	2	36	0	72	76.2	48	26	24	65	52	11	40	23
RMF 300-443-37G0-080-12xM8	TP 050S-MF*	3	37	0	111	117.2	81.5	31	29	69	53.5	1	39	15.5
RMF 400-443-40G0-125-12xM10	TP 110S-MF*	4	40	0	160	168.2	115	41	39	91	70.5	1	51	20.5
RMF 1000-443-36G0-260-16xM30	TP 4000S-MA	10	36	0	360	380.1	269	101	99	236	185.5	1	136	50.5

* also applies to TK*, TPK*, TPC*

m = Module

z = Number of teeth

d = Pitch circle diameter

x = Profile correction factor

d_a = Tip diameter

Refer to the respective gearbox catalog for the exact gearbox dimensions.

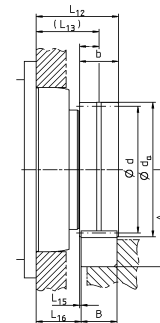

Rotary systems with straight toothing – Advanced Segment

TP+ and TPK+ HIGH TORQUE with straight-toothed RMW preferred pinion

Pinion	TP+ / TPK+ HIGH TORQUE						Set consisting of lubrication pinion and axis ¹⁾
	010 ²⁾	025	050	110	300	500	
Ordering code	F_{2T}^* [N]	F_{2T}^* [N]	F_{2T}^* [N]	F_{2T}^* [N]	F_{2T}^* [N]	F_{2T}^* [N]	Ordering code
RMW 200-444-22G0-037	3510						LMT 200-PU -17G0-020-1
RMW 200-444-22G0-037		4340					LMT 200-PU -17G0-020-1
RMW 300-444-21G0-055		4200					LMT 300-PU -17G0-030-1
RMW 300-444-21G0-055			11400				LMT 300-PU -17G0-030-1
RMW 400-444-22G0-073			10900				LMT 400-PU -17G0-040-1
RMW 400-444-22G0-073				21900			LMT 400-PU -17G0-040-1
RMW 500-444-21G0-089				21200			LMT 500-PU -17G0-050-1
RMW 500-444-21G0-089					34000		LMT 500-PU -17G0-050-1
RMW 600-444-20G0-106					33000		LMT 600-PU -17G0-060-1
RMW 600-444-20G0-106						44300	LMT 600-PU -17G0-060-1
RMW 800-444-19G0-128						41500	LMT 800-PU -17G0-080-1

* F_{2T} Tangential force / feed force – adhere to the permissible tangential force of mating gear

¹⁾ See page 118 for further information on the lubricator and lubrication system

²⁾ not with TPK+

Also available with V-Drive VT*

Application-specific dimensioning with cymex® – www.wittenstein-cymex.com

Pinion designation	Gearbox size	m [mm]	z []	x []	d [mm]	d_a [mm]	$A \pm 0.3$ [mm]	b [mm]	B [mm]	L_{12} [mm]	L_{13} [mm]	L_{15} [mm]	L_{16} [mm]	l_{Fa} [mm]
RMW 200-444-22G0-037	TP 010S-MA*	2	22	0.3	44	49.5	44.6	26	24	71	50.5	8.5	38.5	20.5
RMW 200-444-22G0-037	TP 025S-MA*	2	22	0.3	44	49.5	44.6	26	24	73.5	53	12	41	24
RMW 300-444-21G0-055	TP 025S-MA*	3	21	0.4	63	71.7	58.7	31	29	76	52.5	9	38	23.5
RMW 300-444-21G0-055	TP 050S-MA*	3	21	0.4	63	71.7	58.7	31	29	89.5	66	13.5	51.5	28
RMW 400-444-22G0-073	TP 050S-MA*	4	22	0.2	88	97.9	79.8	41	39	97	67.5	10	48	29.5
RMW 400-444-22G0-073	TP 110S-MA*	4	22	0.2	88	97.9	79.8	41	39	112.5	83	13.5	63.5	33
RMW 500-444-21G0-089	TP 110S-MA*	5	21	0.4	105	119.3	88.5	51	49	120	85	10.5	60.5	35
RMW 500-444-21G0-089	TP 300S-MA*	5	21	0.4	105	119.3	88.5	51	49	139	104	13.5	79.5	38
RMW 600-444-20G0-106	TP 300S-MA*	6	20	0.4	120	137.1	105.4	61	59	142.5	106	10.5	76.5	40
RMW 600-444-20G0-106	TP 500S-MA*	6	20	0.4	120	137.1	105.4	81	59	155	118.5	14	89	43.5
RMW 800-444-19G0-128	TP 500S-MA*	8	19	0.4	152	174.7	150.2	19	79	174	128.5	14	89	53.5

* also applies to TPK* HIGH TORQUE

m = Module

z = Number of teeth

d = Pitch circle diameter

x = Profile correction factor

d_a = Tip diameter

Refer to the respective gearbox catalog for the exact gearbox dimensions.

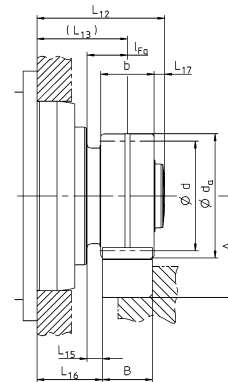

Rotary systems with straight toothing – Premium Segment

RP+, RPM+, RPK+ and RPC+ with straight-toothed RMW preferred pinion

Pinion	RP+ / RPM+ / RPK+ / RPC+					Set consisting of lubrication pinion and axis ¹⁾
	30	40	50	60	80	
Ordering code	F_{2T}^* [N]	F_{2T}^* [N]	F_{2T}^* [N]	F_{2T}^* [N]	F_{2T}^* [N]	Ordering code
RMW 200-444-22G0-037	9950	–	–	–	–	LMT 200-PU -17G0-020-1
RMW 300-444-21G0-055	13800	–	–	–	–	LMT 300-PU -17G0-030-1
RMW 300-444-21G0-055	–	20300	–	–	–	LMT 300-PU -17G0-030-1
RMW 400-444-22G0-073	–	21500	–	–	–	LMT 400-PU -17G0-040-1
RMW 500-444-21G0-073	–	18000	–	–	–	LMT 500-PU -17G0-050-1
RMW 500-444-25G0-106	–	–	47800	–	–	LMT 500-PU -17G0-050-1
RMW 600-444-20G0-106	–	–	48600	–	–	LMT 600-PU -17G0-060-1
RMW 600-444-25G0-128	–	–	–	73000	–	LMT 600-PU -17G0-060-1
RMW 800-444-19G0-128	–	–	–	69400	–	LMT 800-PU -17G0-080-1
RMW 800-444-23G0-156	–	–	–	–	108000	LMT 800-PU -17G0-080-1

* F_{2T} Tangential force / feed force – adhere to the permissible tangential force of mating gear

¹⁾ See page 118 for further information on the lubricator and lubrication system

RPM+ available in customized version

Also available with V-Drive VT*

Application-specific dimensioning with cymex® – www.wittenstein-cymex.com

XP+, XPK+, XPC+ and PHG R with straight-toothed RMW preferred pinion

Pinion	XP+ / XPK+ / XPC+			Set consisting of lubrication pinion and axis ¹⁾
	020	030	040	
Ordering code	F_{2T}^* [N]	F_{2T}^* [N]	F_{2T}^* [N]	Ordering code
RMW 200-444-22G0-033	5600	–	–	LMT 200-PU -17G0-020-1
RMW 200-444-22G0-037	–	8400	–	LMT 300-PU -17G0-030-1
RMW 300-444-21G0-037	–	7400	–	LMT 300-PU -17G0-030-1
RMW 300-444-21G0-055	–	–	10800	LMT 300-PU -17G0-030-1
RMW 400-444-22G0-055	–	–	10800	LMT 400-PU -17G0-040-1
	2	3		
	PHG R			

* F_{2T} Tangential force / feed force – adhere to the permissible tangential force of mating gear

¹⁾ See page 118 for further information on the lubricator and lubrication system

RPM+ available in customized version

Also available with V-Drive VT*

Application-specific dimensioning with cymex® – www.wittenstein-cymex.com

Pinion designation	Gearbox size	m [mm]	z []	x []	d [mm]	d_a [mm]	$A \pm 0.3$ [mm]	b [mm]	B [mm]	L_{12} [mm]	L_{13} [mm]	L_{15} [mm]	L_{16} [mm]	L_{17} [mm]	l_{Fq} [mm]
RMW 200-444-22G0-037	RP 030S*	2	22	0.3	44	49.5	44.6	26	24	83.5	65	12	53	5.5	24
RMW 300-444-21G0-055	RP 030S*	3	21	0.4	63	71.7	58.7	31	29	86	64.5	9	50	6	23.5
RMW 300-444-21G0-055	RP 040S*	3	21	0.4	63	71.7	58.7	31	29	97.6	76	13.5	61.5	6.1	28
RMW 400-444-22G0-073	RP 040S*	4	22	0.2	88	97.9	79.8	41	39	105.1	77.5	10	58	7.1	29.5
RMW 500-444-21G0-073	RP 040S*	5	21	0.4	105	119.3	88.5	51	49	116	83	10.5	58.5	7.5	35
RMW 500-444-25G0-106	RP 050S*	5	25	0.2	125	137.3	97.5	51	49	131.1	98	13.5	73.5	7.6	38
RMW 600-444-20G0-106	RP 050S*	6	20	0.4	120	137.1	105.4	61	59	138.5	100	10.5	70.5	8	40
RMW 600-444-25G0-128	RP 060S*	6	25	0	150	162.3	118	61	59	153.2	113.5	14	84	9.2	43.5
RMW 800-444-19G0-128	RP 060S*	8	19	0.4	152	174.7	150.2	81	79	173	123.5	14	84	9	53.5
RMW 800-444-23G0-156	RP 080S*	8	23	0.2	184	203.5	164.6	81	79	186.6	133.4	14	93.9	12.7	53.5

* also applies to RPM*, RPK*, RPC*

m = Module
 z = Number of teeth
 d = Pitch circle diameter
 x = Profile correction factor
 d_a = Tip diameter

Refer to the respective gearbox catalog for the exact gearbox dimensions.

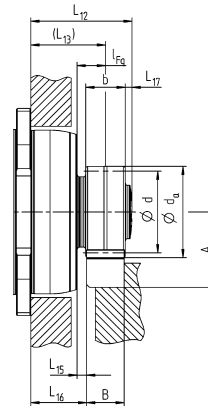

Pinion designation	Gearbox size	m [mm]	z []	x []	d [mm]	d_a [mm]	$A \pm 0.3$ [mm]	b [mm]	B [mm]	L_{12} [mm]	L_{13} [mm]	L_{15} [mm]	L_{16} [mm]	L_{17} [mm]	l_{Fq} [mm]
RMW 200-444-22G0-033	XP 020R*	2	22	0.3	44	49.5	44.6	26	24	59.3	40.8	9	28.8	5.5	20
RMW 200-444-22G0-037	XP 030R*	2	22	0.3	44	49.5	44.6	26	24	69.5	51	12	39	5.5	21
RMW 300-444-21G0-037	XP 030R*	3	21	0.4	63	71.7	58.7	31	29	76.5	54	9	39.5	7	24
RMW 300-444-21G0-055	XP 040R*	3	21	0.4	63	71.7	58.7	31	29	75.5	54	9.5	39.5	6	24
RMW 400-444-22G0-055	XP 040R*	4	22	0.2	88	97.9	79.8	41	39	86.5	59	9.5	39.5	7	29

* also applies to XPK*, XPC*

m = Module
 z = Number of teeth
 d = Pitch circle diameter
 x = Profile correction factor
 d_a = Tip diameter

Refer to the respective gearbox catalog for the exact gearbox dimensions.

