

Shrink discs

Shrink discs are mainly used in hollow-shaft connections

With our hollow shaft or blind hollow shaft gearboxes for the direct assembly on load shafts, machines can be designed for minimal installation space. Technically adjusted to the gearbox, these shrink discs offer safety even in the event of an emergency stop. Thanks to the simple assembly and/or disassembly, they can be re-used several times without compromising on their performance.



PRODUCT HIGHLIGHTS

Reliable and secure torque transmission

thanks to the backlash-free frictional connection.

Huge installation space reduction

due to the omission of constructive intermediate elements.

Reusable multiple times

thanks to almost no wear.

High dynamics and smooth running

thanks to the excellent true-running accuracy.

Versatile application options

thanks to corrosion-resistant materials, also in food-grade applications.

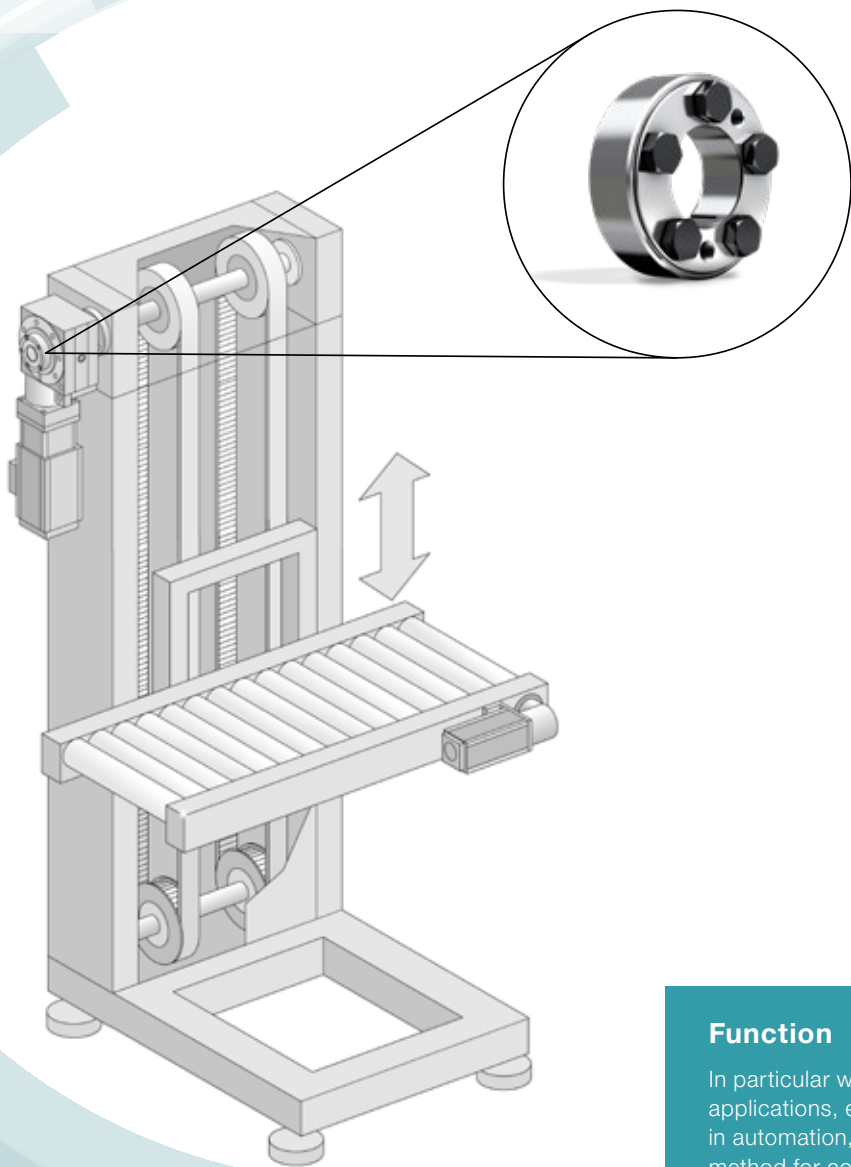

Function

In particular with installation-space critical applications, e.g. **belt and lifting conveyors** in automation, shrink discs are a proven method for connecting drive units.

Shrink discs are inserted above the hollow shaft of the drive, producing a completely backlash-free friction-type connection between the shaft and the hub. The assembly is very easy and is implemented with high-strength screws and defined torque.



Application

Example applications



Machine tools



Drive technology



Wood industry



Food industry



General mechanical engineering



Benefits

Reliable transmission of torques through validated calculations.

Great reduction of installation space thanks to the direct connection to the hollow shaft gearbox.

Reusable multiple times due to the simple screw system.

High true-running accuracy thanks to the precise, symmetrically structured components.

Properties

Transmission of torques without backlash thanks to the high power transmission.

Easy assembly and disassembly thanks to the screw system.

Equal distribution of the applied forces around the scope thanks to a positive connection.

Non-destructive removal through relieving the tension of the screws.

Quick shrink disc selection

Gearbox		Version			Geometry					
		Standard	Nickel-plated	Stainless steel	d	D	A	H*	H2*	J [kgcm ²]
HG ⁺ / SP ⁺ / SPK ⁺ 060	Ordering code	SD 018x044 S2	SD 018x044 N2	SD 018x044 E2	18	44	30	15	19	0.252
	Material number	20000744	20048496	20048491						
	T _{max} [Nm]	100	51	51						
HG ⁺ / SP ⁺ / SPK ⁺ 075	Ordering code	SD 024x050 S2	SD 024x050 N2	SD 024x050 E2	24	50	36	18	22	0.729
	Material number	20001389	20047957	20043198						
	T _{max} [Nm]	250	136	136						
HG ⁺ / SP ⁺ / SPK ⁺ 100	Ordering code	SD 036x072 S2	SD 036x072 N2	SD 036x072 E2	36	72	52	22	27.5	3.94
	Material number	20001391	20048497	20035055						
	T _{max} [Nm]	650	575	450						
HG ⁺ / SP ⁺ / SPK ⁺ 140	Ordering code	SD 050x090 S2	SD 050x090 N2	SD 050x090 E2	50	90	68	26	31.5	11.1
	Material number	20001394	20048498	20047937						
	T _{max} [Nm]	1320	1015	770						
HG ⁺ / SP ⁺ / SPK ⁺ 180	Ordering code	SD 068x115 S2	SD 068x115 N2	SD 068x115 E2	68	115	86	29	34.5	31.1
	Material number	20001396	20048499	20048492						
	T _{max} [Nm]	2450	1820	1500						
VH ⁺ / NVH / CVH 040	Ordering code	SD 024x050 S2	SD 024x050 N2	SD 024x050 E2	24	50	36	18	22	0.729
	Material number	20001389	20047957	20043198						
	T _{max} [Nm]	250	136	136						
VH ⁺ / NVH / CVH 050	Ordering code	SD 030x060 S2V	SD 030x060 N2	SD 030x060 E2	30	60	44	20	24	1.82
	Material number	20020687	20047934	20047885						
	T _{max} [Nm]	550	375	230						
VH ⁺ / NVH / CVH 063	Ordering code	SD 036x072 S2V	SD 036x072 N2V	SD 036x072 E2	36	72	52	22	27.5	3.94
	Material number	20020688	20047530	20035055						
	T _{max} [Nm]	640	560	450						
VH ⁺ 080	Ordering code	SD 050x090 S2V	SD 050x090 N2V	SD 050x090 E2	50	90	68	26	31.5	11.1
	Material number	20020689	20047935	20047937						
	T _{max} [Nm]	1400	950	900						
VH ⁺ 100	Ordering code	SD 062x110 S2V	SD 062x110 N2	SD 062x110 E2	62	110	80	29	34.5	27
	Material number	20020690	20047927	20047860						
	T _{max} [Nm]	2300	1540	1000						

*Applicable to the unclamped condition. ** Maximum torque without axial forces. Shrink discs suitable for XP⁺ and PKF gearboxes upon request

For the operation, one shrink disc for each gearbox is sufficient.
Please refer to the operating manual for information on the correct shrink disc installation.
The instructions are enclosed with the order.

Assembly/operating manual available under www.wittenstein-alpha.de/downloads

Recommendation for the load shaft:
Tolerance h6
Surface roughness ≤ Rz 16
Minimum yield strength $R_p 0.2 \geq 385 \text{ N/mm}^2$

The shrink disc is not included in the scope of delivery of the gearbox. It must therefore be ordered separately (for the V-Drive gearbox type, this is possible in the ordering code).

