

Technical documents

LP⁺/ LPB⁺ Generation 3



Revision history

Revision	Date	Comment	Chapter
01	20.01.03	new version	all
02	16.01.07	technical data updated	6.4.1
03	22.12.08	technical data updated Layout WITTENSTEIN	all
04	01.08.09	Machinery Directive	1, 2, 3, 4, 6
05	07.09.10	technical data updated	5.4, 9.1
06	16.05.10	Generation 3	all
07	08.04.15	Safety; DIN	2.7, 5.1; 9.2
08	31.01.17	Adapter plate	5,1, 5.3.2
09	20.10.23	Technical documents	Cover sheet

Service

In case you have technical questions,
please contact:

WITTENSTEIN alpha GmbH

Customer Service
Walter-Wittenstein-Straße 1
D-97999 Igersheim

Tel.: +49 7931 493-12900

Fax: +49 7931 493-10903

E-mail: service-alpha@wittenstein.de

© WITTENSTEIN alpha GmbH 2023

This documentation is copyright protected.

WITTENSTEIN alpha GmbH reserves all the rights to photo-mechanical reproduction, copying, and the distribution by special processes (such as computers, file media, data networks), even in parts.

Subject to technical and content changes without notice.

Contents

1	About this manual	2
1.1	Signal words	2
1.2	Safety symbols.....	3
1.3	Design of the safety instructions	3
1.4	Information symbols.....	3
2	Safety	4
2.1	EC directives	4
2.1.1	Machinery directive	4
2.1.2	RoHS.....	4
2.2	Dangers	4
2.3	Personnel.....	4
2.4	Intended use	4
2.5	Reasonably foreseeable misuse.....	4
2.6	Guarantee and liability	5
2.7	General safety instructions	5
3	Description of the gearhead	7
3.1	Overview of the gearhead components	7
3.1.1	Overview of the gearhead components LP+	7
3.1.2	Overview of the gearhead components LPB+	7
3.2	Identification plate	8
3.3	Ordering code	8
3.4	Performance data	8
3.5	Weight.....	9
4	Transport and storage	10
4.1	Scope of delivery	10
4.2	Packaging	10
4.3	Transport.....	10
4.4	Storage	10
5	Assembly	11
5.1	Preparations.....	11
5.2	Mounting the gearhead on a machine (LPB+).....	12
5.3	Mounting the motor onto the gearhead (LP+/LPB+).....	14
5.3.1	Pre-mounting adapter plate (LPB+ only)	14
5.3.2	Mounting the motor (LP+ and LPB+)	15
5.4	Components mounted on the output side	16
5.4.1	Mountings on the output flange (LPB+)	16
5.5	Mounting the gearhead on a machine (LP+).....	17
6	Startup and operation	18
7	Maintenance and disposal	19
7.1	Maintenance work.....	19
7.1.1	Visual inspection	19
7.1.2	Checking the tightening torques.....	19
7.2	Startup after maintenance work	19
7.3	Maintenance schedule	19
7.4	Notes on the lubricant used	20
7.5	Disposal	20
8	Malfunctions	21
9	Appendix	22
9.1	Specifications for mounting onto a motor.....	22
9.2	Specifications for mounting onto a machine	22
9.3	Tightening torques for common thread sizes in general mechanical engineering	23

1 About this manual

These instructions contain necessary information for the safe operation of the planetary gearhead LP⁺/LPB⁺, referred to as gearhead in the following.

If this manual is supplied with an amendment (e.g. for special applications), then the information in the amendment is valid. Contradictory specifications in this manual thereby become obsolete.

The operator must ensure that these instructions are read through by all persons assigned to install, operate, or maintain the gearhead, and that they fully comprehend them.

Store these instructions within reach of the gearhead.

These **safety instructions** should be shared with colleagues working in the vicinity of the device to ensure individual safety.

The original instructions were prepared in German; all other language versions are translations of these instructions.

1.1 Signal words

The following signal words are used to bring your attention to dangers, prohibitions, and important information:

	<p style="text-align: center;">⚠ DANGER</p> <p>This signal word points to an imminent danger that can cause serious injuries and even death.</p>
	<p style="text-align: center;">⚠ WARNING</p> <p>This signal word points to a possible danger that can cause serious injuries and even death.</p>
	<p style="text-align: center;">⚠ CAUTION</p> <p>This signal word points to a possible danger that can cause slight to serious injuries.</p>
	<p style="text-align: center;">NOTICE</p> <p>This signal word points to a possible danger that can cause material damage.</p>
	<p>A note without signal word draws your attention to application tips or especially important information when handling the gearhead.</p>

1.2 Safety symbols

The following safety symbols are used to bring your attention to dangers, prohibitions, and important information:



General danger



Hot surface



Suspended loads



Danger of being pulled in



Environment protection



Information

1.3 Design of the safety instructions

The safety instructions of these instructions are designed according to the following pattern:

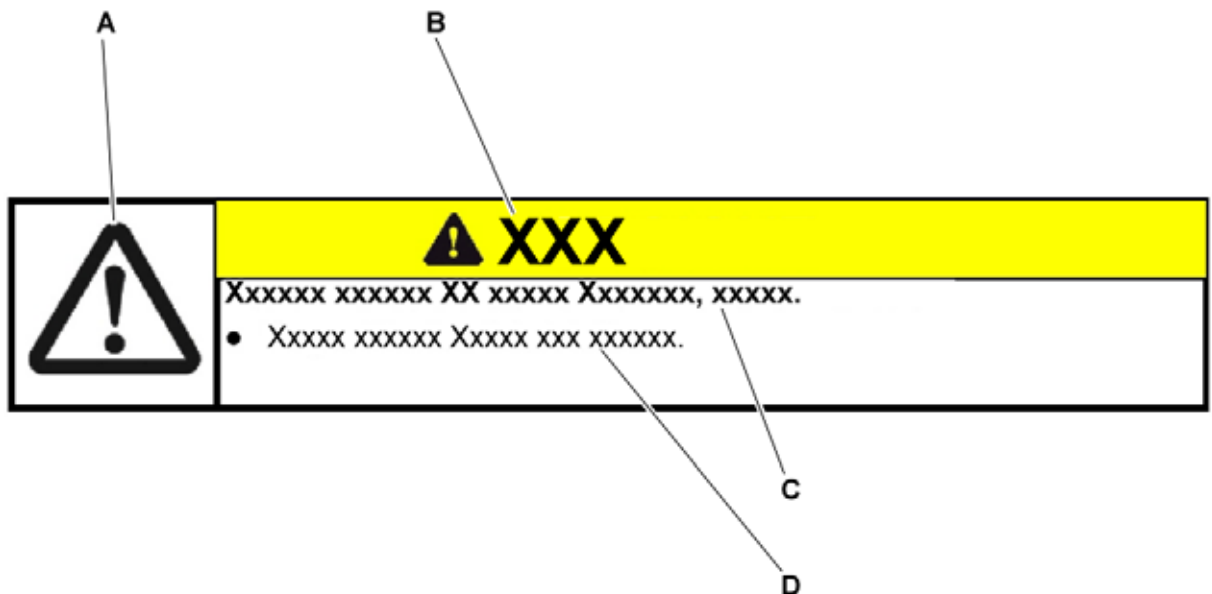

A = Safety symbol (see Chapter 1.2 "Safety symbols")

B = Signal word (see Chapter 1.1 "Signal words")

C = Type and consequence of the danger

D = Prevention of the danger

1.4 Information symbols

The following information symbols are used:

- Indicates an action to be performed
- ➡ Indicates the results of an action
- ⓘ Provides additional information on handling

2 Safety

These instructions, especially the safety instructions and the rules and regulations valid for the operating site, must be observed by all persons working with the gearhead.

In addition to the safety instructions in this manual, also observe any (legal and otherwise) applicable environmental and accident prevention rules and regulations (e.g. personal safety equipment).

2.1 EC directives

2.1.1 Machinery directive

The gearhead is considered a "machine component" and is therefore not subject to the EC Machinery Directive 2006/42/EC.

Operation is prohibited within the area of validity of the EC directive until it has been determined that the machine in which this gearhead is installed corresponds to the regulations within this directive.

2.1.2 RoHS

The homogeneous materials used in the gearhead fall below the amounts of hazardous materials limited by directive 2011/65/EU Annex II.

- Lead (0.1%)
- Mercury (0.1%)
- Cadmium (0.01%)
- Hexavalent chromium (0.1%)
- Polybrominated biphenyls (PBB) (0.1%)
- Polybrominated diphenyl ether (PBDE) (0.1%)

Installation of the gearhead therefore has no effect on the restriction of using certain hazardous materials in electrical and electronic equipment as required in the directive.

2.2 Dangers

The gearhead has been constructed according to current technological standards and accepted safety regulations.

To avoid danger to the operator or damage to the machine, the gearhead may be put to use only for its intended usage (see chapter 2.4 "Intended use") and in a technically flawless and safe state.

- Read the general safety instructions before beginning work (see Chapter 2.7 "General safety instructions").

2.3 Personnel

Only persons who have read and understood these instructions may carry out work on the gearhead.

2.4 Intended use

The gearhead serves to convert torques and speeds. It is suitable for all industrial applications.

The gearhead may not be operated in areas with explosion hazards. In food processing, the gearhead may be used only next to or under the foodstuff area.

The gearhead is intended for installation on motors that:

- Correspond to the design B5 (in the event of deviations, consult our Customer Service department [technical Customer Service department]).
- Have a radial and axial runout tolerance according to DIN EN 50347.
- Have a cylindrical shaft end with tolerance class h6 to k6.

2.5 Reasonably foreseeable misuse





Any use that deviates from the approved technical data (e.g. speed, force, torque, temperature) is not use as intended and is therefore not permitted.



2.6 Guarantee and liability

Guarantee and liability claims are excluded for personal injury and material damage in case of

- Ignoring the information on transport and storage
- Improper use (misuse)
- Improper or neglected maintenance and repair
- Improper assembly / disassembly or improper operation (e.g. test run without secure attachment)
- Operation of the gearhead when safety devices and equipment are defective
- Operation of the gearhead without lubricant
- Operation of a heavily soiled gearhead
- Modifications or reconstructions that have been carried out without the approval of **WITTENSTEIN alpha GmbH**

2.7 General safety instructions

	<p style="text-align: center;">⚠ WARNING</p> <p>Objects flung out by rotating components can cause serious injuries.</p> <ul style="list-style-type: none"> • Remove objects and tools from the gearhead before putting it into operation. • Remove/Secure the shaft key (if available) if the gearhead is operated without attachments on the output/drive side.
	<p style="text-align: center;">⚠ WARNING</p> <p>Rotating components on the gearhead can pull in parts of the body and cause serious injuries and even death.</p> <ul style="list-style-type: none"> • Keep a sufficient distance to rotating machinery while the gearhead is running. • Secure the machine against restarting and unintentional movements during assembly and maintenance work (e.g. uncontrolled lowering of lifting axes).
	<p style="text-align: center;">⚠ WARNING</p> <p>A damaged gearhead can cause accidents and injury.</p> <ul style="list-style-type: none"> • Never use a gearhead that has been overloaded to due misuse or a machine crash (see chapter 2.5 "Reasonably foreseeable misuse"). • Replace the affected gearhead, even if no external damage is visible.
	<p style="text-align: center;">⚠ CAUTION</p> <p>Hot gearhead housing can cause serious burns.</p> <ul style="list-style-type: none"> • Touch the gearhead housing only when wearing protective gloves or after the gearhead has been at standstill for some time.
	<p style="text-align: center;">NOTICE</p> <p>Loose or overloaded screw connections can damage the gearhead.</p> <ul style="list-style-type: none"> • Use a calibrated torque wrench to tighten and check all screw connections for which a tightening torque has been specified.

	<p style="text-align: center;">⚠ WARNING</p> <p>Lubricants are flammable.</p> <ul style="list-style-type: none"> • Do not spray with water to extinguish. • Suitable extinguishing agents are powder, foam, water mist, and carbon dioxide. • Observe the safety instructions of the lubricant manufacturer (see Chapter 7.4 "Notes on the lubricant used").
	<p style="text-align: center;">⚠ CAUTION</p> <p>Solvents and lubricants can cause skin irritations.</p> <ul style="list-style-type: none"> • Avoid direct skin contact.
	<p>Solvents and lubricants can pollute soil and water.</p> <ul style="list-style-type: none"> • Use and dispose of cleaning solvents and lubricants properly.

3 Description of the gearhead

The gearhead is a single or multistage planetary gearhead which is manufactured in the version "M" (motor-mounted) by default. The output shaft bearing is realized in such a manner that it can accommodate extensive tilting moments and axial forces.

For applications with special safety requirements (e.g. vertical axes, distorted gear inputs) we recommend employing exclusively our products alpheno[®], RP⁺, SP⁺, TP⁺, TP⁺ HIGH TORQUE or consulting with **WITTENSTEIN alpha GmbH**.

The motor centering is realized via the held receptacle for tabs, and not via the adapter plate. Radial clamping of the motor is avoided.

An adaptation to various motors is realized via an adapter plate and a bushing.

The optional LPB⁺ has an output flange instead of an output shaft. This provides the option of mounting a toothed belt pulley.

3.1 Overview of the gearhead components

3.1.1 Overview of the gearhead components LP⁺

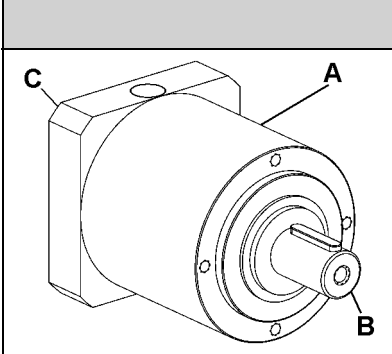
		Gearhead components LP ⁺
	A	Gearhead housing
	B	Output shaft
	C	Adapter plate

Tbl-1: Overview of the gearhead components

3.1.2 Overview of the gearhead components LPB⁺

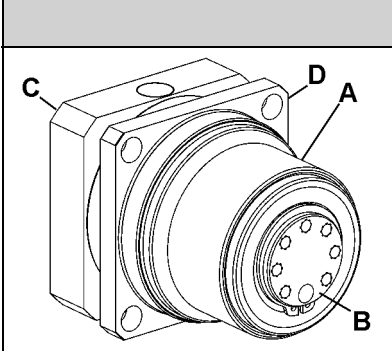
		Gearhead components LPB ⁺
	A	Gearhead housing
	B	Output flange
	C	Adapter plate
	D	Mountable flange

Tbl-2: Overview of the gearhead components

3.2 Identification plate

The identification plate is attached to the gearhead housing.

		Designation
	A	Ordering code (see Chapter 3.3 "Ordering code")
	B	Ratio
	C	Serial number
	D	Lubrication information
	E	Production date

Tbl-3: Identification plate (sample values)

3.3 Ordering code

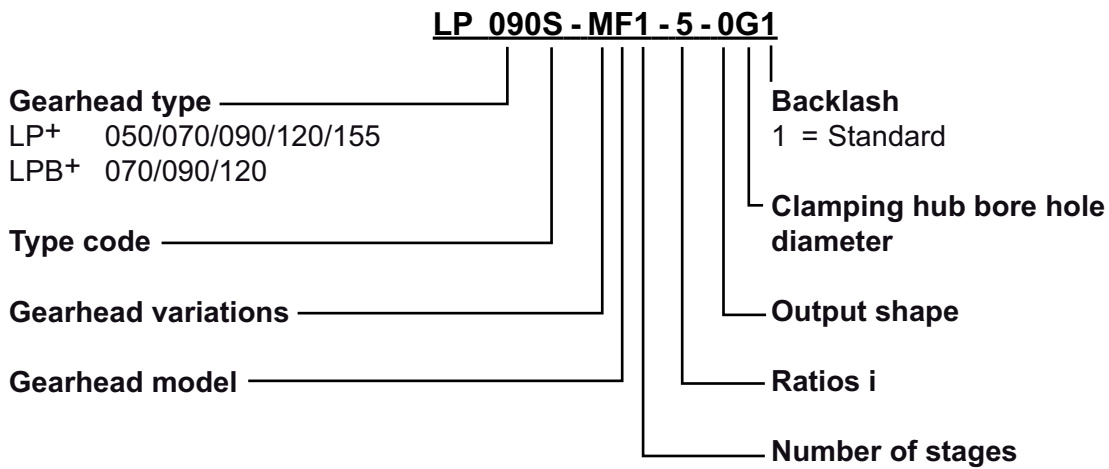

Refer to our catalog or our website at www.wittenstein-alpha.de for further information.

3.4 Performance data

For the maximum permitted speeds and torques, refer to

- our catalog,
- our website www.wittenstein-alpha.de,
- the respective customer-specific performance data (X093–D...).

	<p>Consult our Customer Service department if the gearhead is older than a year. You will then receive the valid performance data.</p>
--	---

3.5 Weight

The table "Tbl-4" specifies the gearhead dimensions with medium-sized adapter plate. If a different adapter plate is mounted, the actual dimensions can deviate by up to 20%.

Gearhead size LP⁺	050	070	090	120	155
1-stage [kg]	0.75	2.0	4.0	8.6	17.0
2-stage [kg]	0.95	2.4	5.0	11.0	21.0
Gearhead size LPB⁺	050	070	090	120	155
1-stage [kg]	—	1.6	3.3	7.3	—
2-stage [kg]	—	2.0	4.3	9.7	—

Tbl-4: Weight

4 Transport and storage

4.1 Scope of delivery



- Check the completeness of the delivery against the delivery note.
 - ① Immediately notify the carrier, the insurance company, or **WITTENSTEIN alpha GmbH** in writing of any missing parts or damage.

4.2 Packaging

The gearhead is delivered packed in foil and cardboard boxes.

- Dispose of the packaging materials at recycling sites intended for that. Observe the locally valid regulations for disposals.

4.3 Transport

	⚠ WARNING
	<p>Suspended loads can fall and can cause serious injuries and even death.</p> <ul style="list-style-type: none"> • Do not stand under suspended loads. • Secure the gearhead before transport with suitable fasteners (e.g. belts).
	NOTICE
	<p>Hard knocks, because of falling or hard dropping, can damage the gearhead.</p> <ul style="list-style-type: none"> • Only use hoisting equipment and transports with sufficient capacity. • The maximum permitted lift capacity of a hoist may not be exceeded. • Lower the gearhead slowly.

No special transport mode is prescribed for transporting the gearhead.

Specifications on the weights, refer to Chapter 3.5 "Weight".

4.4 Storage

Store the gearhead in horizontal position and dry surroundings at a temperature of 0 °C to +40 °C in the original packaging. Store the gearhead for a maximum of 2 years. Consult our Customer Service department if the conditions are different.

For storage logistics, we recommend the "first in –first out" method.

5 Assembly

- Read the general safety instructions before beginning work (see Chapter 2.7 "General safety instructions").

The gearhead can be used in any mounting position.

- ① For applications with special safety requirements (e.g. vertical axes, distorted gear inputs) we recommend employing exclusively our products **alpheno®**, **RP+**, **SP+**, **TP+**, **TP+ HIGH TORQUE** or consulting with **WITTENSTEIN alpha GmbH**.

5.1 Preparations

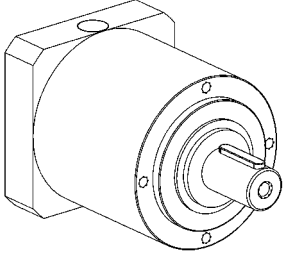
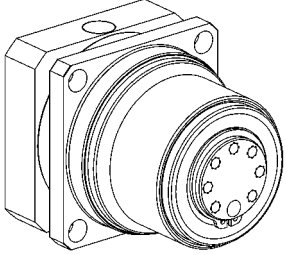

The different assembly sequences for **LK+** and **LPB+** are listed in the table "Tbl-5".

- ① Our Customer Service department is available to answer any questions.

LP+		LPB+	
	—	1 5.2 "Mounting the gearhead on a machine (LPB+)"	
	1 5.3 "Mounting the motor onto the gearhead (LP+/LPB+)"	2 5.3 "Mounting the motor onto the gearhead (LP+/LPB+)"	
	2 5.4 "Components mounted on the output side"	3 5.4 "Components mounted on the output side"	
	3 5.5 "Mounting the gearhead on a machine (LP+)"	—	

Tbl-5: Assembly sequence

The bolts for mounting are not included in the scope of delivery and need to be provided by the customer. Information can be found in the individual assembly steps.

	NOTICE
	<p>Pressurized air can damage the gearhead seals.</p> <ul style="list-style-type: none"> • Do not use pressurized air to clean the gearhead.
	NOTICE
	<p>Directly sprayed cleaning agents can alter the frictional values of the clamping hub.</p> <ul style="list-style-type: none"> • Only spray cleaning agents onto a cloth for wiping off the clamping hub.

In rare situations, for a gearhead with grease lubrication, a leak can occur at the drive (seeping).

To avoid seeping, we recommend that the surfaces between

- adapter plate and drive housing (gearhead) as well as
- adapter plate and motor

using a surface sealing adhesive (e.g. Loctite® 573 or 574).

- For more information, please contact our Customer Service department.

	NOTICE
	<p>Operation without an adapter plate can lead to damage.</p> <ul style="list-style-type: none"> • Only install your own adapter plate or replace an adapter plate according to the specifications of WITTENSTEIN alpha GmbH. Our customer service will provide you with disassembly instructions for this purpose. • Operation without an adapter plate is prohibited.

- Make sure that motor meets the specifications in Chapter 2.4 "Intended use".
- Clean/De-grease the following components with a clean and lint-free cloth and grease-dissolving, non-aggressive detergent:
 - All fitting surfaces to neighboring components
 - Centering
 - The motor shaft
 - The inner diameter of the plug receptacle
 - The bushing, inside and out
- Check the fitting surfaces additionally for damage and impurities.

5.2 Mounting the gearhead on a machine (LPB+)

	<ul style="list-style-type: none"> • Observe the safety and processing instructions of the cleaning agents and threadlocker to be used.
--	--

There are two centering mechanisms for assembling the gearhead to the machine:

		centering
	A	motor side
	B	gear output side

Tbl-6: Centering mechanisms

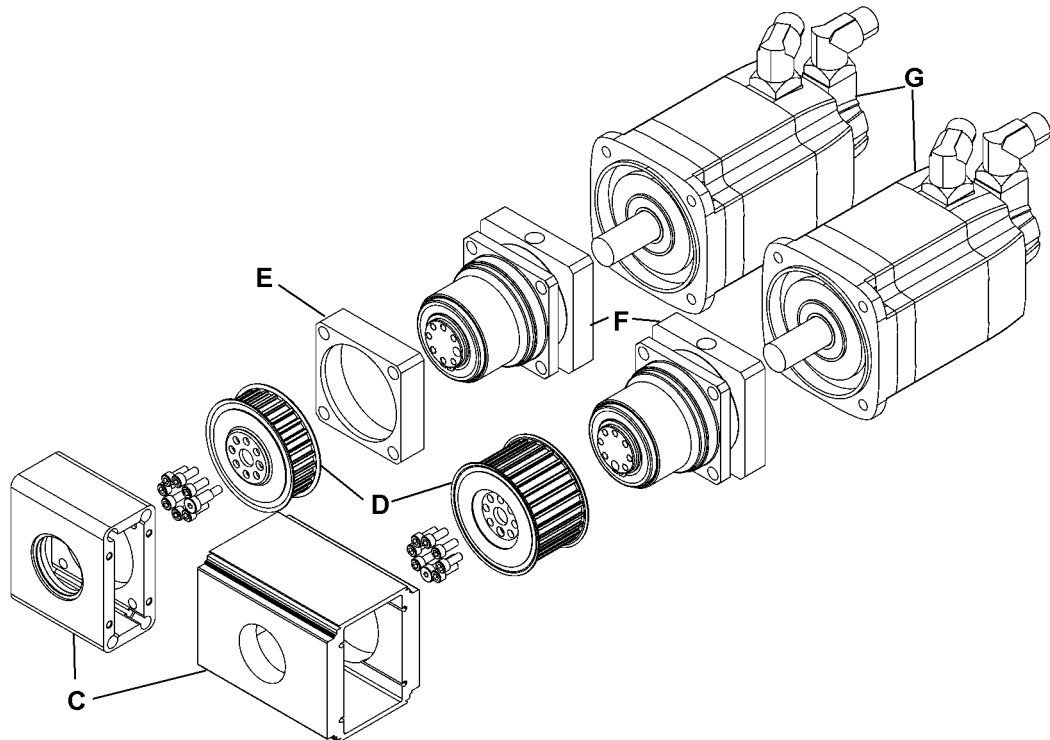

- ① If necessary, a spacer (E) may need to be placed between the gear reducer and your machine to position the gear reducer precisely. Such a spacer is **not** part of the drive's delivery and needs to be provided by the customer.
- Thoroughly clean the output flange, centering, fitting surface, spacer and toothed belt pulley. The anti-corrosion agent on the toothed belt pulley must be removed.
 - ① To remove the anti-corrosion agent, use acetone or Loctite[®] 7063, and a clean, lint-free cloth.
- Also clean the browned toothed belt pulley with a brush and remove any salt residue between the flanged wheel and toothed belt wheel.

The fastening screws need to be provided by the customer.

- ① The prescribed screw sizes and tightening torques can be found in Chapter 9.2 "Specifications for mounting onto a machine", Table "Tbl-17".
- ① When using hollow profiles (C): Position the toothed belt pulley (D) in the hollow profile before attaching the gearhead.
- Apply threadlocker (e.g., Loctite[®] 243) to the fastening screws.
- Fasten the gearhead to the machine with the fastening screws through the through-holes.
- ① Mount the gearhead in such a way that the type plate remains legible, if possible.
- ① Do not use washers (e.g. plain washers, tooth lock washers).

5.3 Mounting the motor onto the gearhead (LP⁺/ LPB⁺)

The standard delivery of a gearhead does not include a motor. The motor to be mounted has to:

- correspond to the B5 design
- have a radial and axial runout tolerance according to DIN EN 50347
- and if possible, have a smooth shaft.

① If a motor is included in the delivery, then it is:

- already firmly mounted on the LP⁺ (no assembly necessary).
- only mounted hand-tight on the LPB⁺ (assembly necessary).

5.3.1 Pre-mounting adapter plate (LPB⁺ only)

The following information is valid for only the LPB⁺. On the LP⁺, the adapter plate is already mounted.

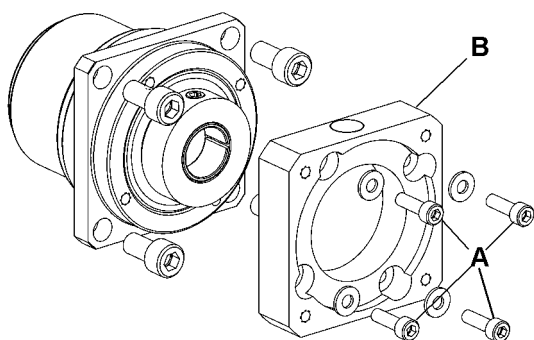

The adapter plate (B) along with the four fastening screws (A) are included in the scope of delivery of the gearhead.

- Place the adapter plate onto the gearhead housing and hand-tighten the screws at first.
- Tighten the screws in diagonal order in at least two passes to the required tightening torque. See Table "Tbl-7"

Gearhead size LPB ⁺	Size	Tightening torque [Nm]
070	M4	2,6
090	M6	9,0
120	M6	9,0

Tbl-7: Fastening screws of the adapter plate

5.3.2 Mounting the motor (LP+ and LPB+)

- Observe the specifications and safety instructions of the motor manufacturer.
- Observe the safety and processing instructions for the threadlocker to be used.

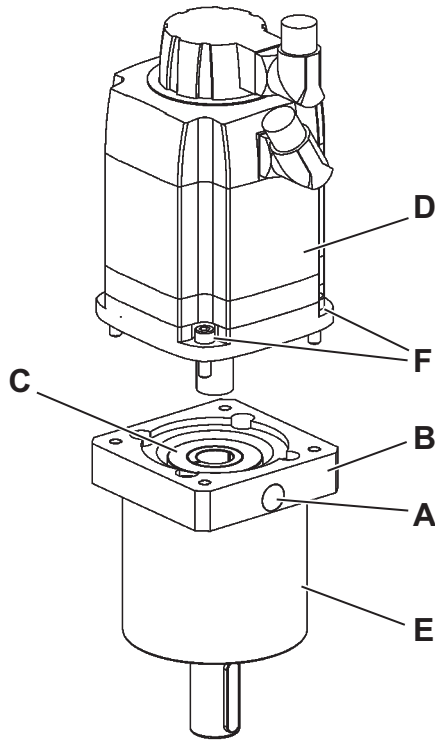

- Ensure that the motor is mounted if possible in a vertical direction.
- If the motor shaft has a shaft key, remove it.
 - ① If recommended by the motor manufacturer, insert a half wedge.
- Turn the plug receptacle (C) so that the threaded pin (H) can be reached through the mounting bore.
- Push the motor shaft into the plug receptacle of the gearhead.
 - ① The maximum permitted axial forces may not be exceeded, see Chapter 9.1 "Specifications for mounting onto a motor", Table "Tbl-15". The motor shaft should slip in easily. If this is not the case, the threaded pin needs to be loosened more.
 - ① The slot of the bushing has to line up with the groove (if present) of the motor shaft and be rotated by 90° against the threaded pin; see Table "Tbl-8" .
 - ① No gap is permitted between motor (D) and the adapter plate (B).

		Designation	
		C	Plug receptacle
		H	Threaded pin
		J	Bushing
		L	Smooth motor shaft
		K	Keyed motor shaft

Tbl-8: Arrangement of motor shaft, plug receptacle and bushing

- Smear threadlocker (e.g. Loctite®243) onto the four screws (F).
- Fasten the motor (D) onto the adapter plate (B) with the four screws. Evenly tighten the screws crosswise with increasing torque.
- Tighten the threaded pin (H) of the plug receptacle (C).
 - ① For screw sizes and prescribed tightening torques, see Chapter 9.1 "Specifications for mounting onto a motor", Table "Tbl-15".
- Press the enclosed stopper plugs (A) up to their stop into the mounting bores of the adapter plate (B).

5.4 Components mounted on the output side

	NOTICE				
	<p>Clamping forces during assembly can damage the gearhead.</p> <ul style="list-style-type: none"> ● Mount the mounting parts onto the output flange without using force. ● Never attempt to assemble by force or hammering! ● Only use suitable tools and devices for assembly. ● Make sure not to exceed the maximum permissible static axial forces on the output bearing (see Table "Tbl-9") when pulling or shrink-fitting a mounting part onto the output shaft. 				

Size LP ⁺ / LPB ⁺	050	070	090	120	155
F_{a max}[N]	1800	4300	5100	11300	18500

Tbl-9: Maximum permissible static axial forces at static load rating (s₀) = 1.8 and radial force (F_r) = 0

5.4.1 Mountings on the output flange (LPB⁺)

	<ul style="list-style-type: none"> ● Observe the safety and processing instructions of the cleaning agents and threadlocker to be used.
--	--

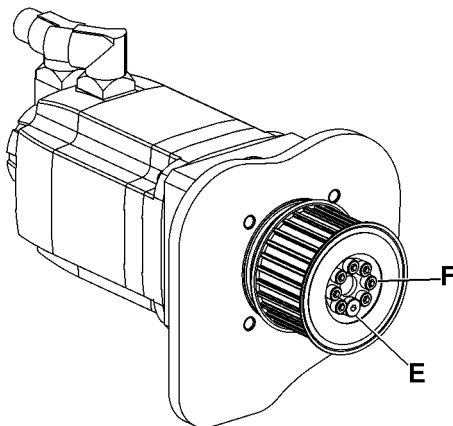

Only the LPB⁺ version features an output flange on which a toothed belt pulley can be mounted with bolts.

- Thoroughly clean the output flange, centering, fitting surface and toothed belt pulley. The anti-corrosion agent on the toothed belt pulley must be removed.
 - ⓘ To remove the anti-corrosion agent, use acetone or Loctite[®] 7063, and a clean, lint-free cloth.
- Also clean the browned toothed belt pulley with a brush and remove any salt residue between the flanged wheel and toothed belt wheel.
- Place the toothed belt pulley onto the output flange.
- Apply threadlocker (e.g., Loctite[®] 243) to the screws, and tighten the screws by hand initially.
- Tighten the fastening screws (F) and the close-tolerance bolt (E) (1 piece) in diagonal order, making at least two passes to the prescribed tightening torque (see table "Tbl-10").

Gearhead size LPB+	Close-tolerance bolt		Fastening screw	
	Thread x depth [mm] x [mm]	Tightening torque [Nm] (Property class 10.9)	Quantity x Thread x Depth [] x [mm] x [mm]	Tightening torque [Nm] (Property class 12.9)
070	M5 x 12	7.69	5 x M5 x 12	9
090	M6 x 16	13.2	7 x M6 x 16	15.4
120	M6 x 16	13.2	7 x M8 x 20	37.3

Tbl-10: Fastening the toothed belt pulley

The tension of the tooth belt is brought about by its construction. The toothed belt's prestressing force influences the ball bearing life of the gearhead.

- Use our **cymex**[®] specification software to determine the theoretical bearing life for each application scenario.
- Set the toothed belt so that there are no lateral starting loads pressing on the toothed belt pulley.

5.5 Mounting the gearhead on a machine (LP+)

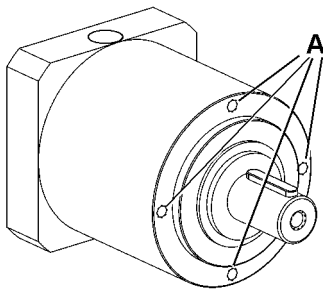

The gearhead housing has four threaded holes for bolting the gearhead to a machine.

- Thoroughly clean the output shaft, centering, and fitting surface.

The bolts need to be provided by the customer. The prescribed screw sizes and tightening torques can be found in Chapter 9.2 "Specifications for mounting onto a machine", Table "Tbl-16".

- Coat four bolts with a threadlocker (e.g., Loctite[®] 243).
- Fasten the gearhead on the machine with the fastening bolt through the holes.
 - ① Mount the gearhead in such a way that the type plate remains legible.
 - ① Do not use washers (e.g. plain washers, tooth lock washers).

6 Startup and operation

- Read the general safety instructions before beginning work (see Chapter 2.7 "General safety instructions").

	<p>Improper use can cause damage to the gearhead.</p> <ul style="list-style-type: none">● Make sure that<ul style="list-style-type: none">- the ambient temperature does not drop below -15 °C or exceed $+40\text{ °C}$ and- the operating temperature does not exceed $+90\text{ °C}$.● Avoid icing, which can damage the seals.● For other conditions of use, consult our Customer Service department.● Only use the gearhead only up to its maximum limit values, see Chapter 3.4 "Performance data".● Only use the gearhead only in a clean, dust-free and dry environment.
--	--

7 Maintenance and disposal

- Read the general safety instructions before beginning work (see Chapter 2.7 "General safety instructions").

7.1 Maintenance work

7.1.1 Visual inspection

- Check the entire gearhead for exterior damage.
- The sealings are subject to wear. Therefore also check the gearhead for leakage during each visual inspection.
 - ① Check the mounting position, so that no foreign medium (e.g. oil) has collected on the output shaft.

7.1.2 Checking the tightening torques

- Check the tightening torque of the fastening screws on the gearhead housing. For LPB⁺ gearheads, also check the fastening screws on the toothed belt pulley.
 - ① The prescribed tightening torques can be found in Chapter 9.2 "Specifications for mounting onto a machine", Tables "Tbl-16" and "Tbl-17", and in Chapter 5.4.1 "Mountings on the output flange (LPB⁺)", Table "Tbl-10".
- Check the tightening torque of the threaded pin on the motor mounting.
 - ① The prescribed tightening torques can be found in Chapter 9.1 "Specifications for mounting onto a motor", Table "Tbl-15".

7.2 Startup after maintenance work

- Clean the outside of the gearhead.
- Attach all safety devices.
- Do a trial run before releasing the gearhead again for operation.

7.3 Maintenance schedule

Maintenance work	At startup	For the first time after 500 operating hours or 3 months	Every 3 months	Yearly
Visual inspection	X	X	X	
Checking the tightening torques	X	X		X

Tbl-11: Maintenance schedule

7.4 Notes on the lubricant used

	All gearheads are lubricated for their service life by the manufacturer with a mineral oil-based lithium soap grease or with a food-safe synthetic grease (carbon hydride oil, aluminum complex soap) (see identification plate). All bearings are permanently lubricated by the company.
---	---

The manufacturer listed below will provide any further information on the lubricants:

Standard lubricants	Lubricants for the food industry (USDA-H1 registered)
Castrol Industrie GmbH, Mönchengladbach Tel.: + 49 2161 909-30 www.castrol.com	Klüber Lubrication München KG, München Tel.: + 49 89 7876-0 www.klueber.com



Tbl-12: Lubricant manufacturers

7.5 Disposal

Consult our Customer Service department for supplementary information on exchanging the adapter plate, on disassembly, and on disposal of the gearhead.

- Dispose of the gearhead at the recycling sites intended for this purpose.
 - ① Observe the locally valid regulations for disposals.

8 Malfunctions

	<p style="text-align: center;">NOTICE</p> <p>Changed operational behavior can be an indication of existing damage to the gearhead or cause damage to the gearhead.</p> <ul style="list-style-type: none"> Do not put the gearhead back into operation until the cause of the malfunction has been rectified.
	<p>Rectifying of malfunctions may only be done by specially trained technicians.</p>

Fault	Possible cause	Solution
Increased operating temperature	The gearhead is not suited for the task.	Check the technical specifications.
	Motor is heating the gearhead.	Check the wiring of the motor.
		Ensure adequate cooling.
	Change the motor.	
Increased noises during operation	Distortion in motor mounting	Consult our Customer Service department.
	Damaged bearings	
	Damaged gear teeth	
	Toothed belt prestension too great	
Loss of lubricant	Lubricant quantity too high	Wipe off discharged lubricant and continue to watch the gearhead. Lubricant discharge should stop after a short time.
	Seals not tight	Consult our Customer Service department.

Tbl-13: Malfunctions

9 Appendix

9.1 Specifications for mounting onto a motor

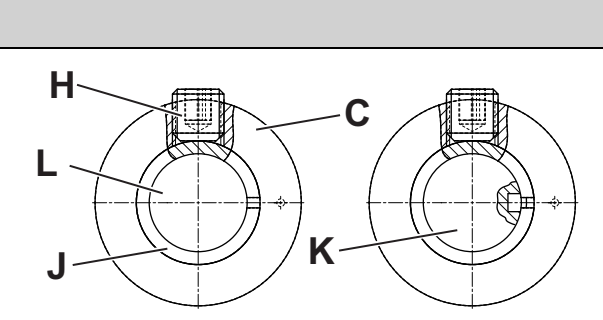
		Designation
	C	Plug receptacle
	H	Threaded pin
	J	Bushing
	L	Smooth motor shaft
	K	Keyed motor shaft

Tbl-14: Arrangement of motor shaft, plug receptacle and bushing

Gearhead size LP ⁺ / LPB ⁺	Max. plug receptacle inside Ø [mm]	Width across flats, threaded pin (H) [mm]	Tightening torque [Nm]	Max. axial force [N]
050	14	3	5.6	45
070	19	4	14	80
090	28	5	23	100
120	38	6	45	150
155, 1-stage	42	8	78	180
155, 2-stage	38	6	45	150

Smaller motor shaft diameter is compensated by means of bushing.
If necessary, consult the Customer Service department.

Tbl-15: Specifications for mounting onto a motor

9.2 Specifications for mounting onto a machine

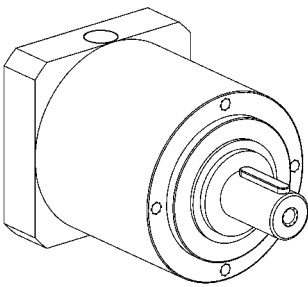
	Gearhead size LP ⁺	Hole circle Ø [mm]	Screw size, property class 12.9		Tightening torque [Nm]
	050	44	M4	DIN EN ISO 4762	4.55
	070	62	M5	DIN EN ISO 4762	9.0
	090	80	M6	DIN EN ISO 4762	15.4
	120	108	M8	DIN EN ISO 4762	37.3
	155	140	M10	DIN EN ISO 4762	73.4

Tbl-16: Threaded bores in gearhead housing LP⁺

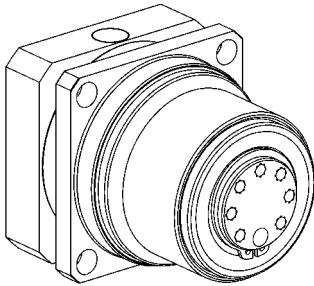
	Gearhead size LPB+	Hole circle Ø [mm]	Screw size, property class 12.9		Tightening torque [Nm]
	070	82	M8	DIN EN ISO 4762	37.3
	090	106	M10	DIN EN ISO 4762	73.4
	120	144	M12	DIN EN ISO 4762 / DIN EN ISO 4017	126

Tbl-17: Through-holes in gearhead housing LPB+

9.3 Tightening torques for common thread sizes in general mechanical engineering

The specified tightening torques for headless screws and nuts are calculated values and are based on the following conditions:

- Calculation in accordance with VDI 2230 (February 2003 version)
- Friction value for thread and contact surfaces $\mu=0.10$
- Exploitation of the yield stress 90%
- Torque tools type II classes A and D in accordance with ISO 6789

The settings are values rounded to usual commercial scale gradations or setting possibilities.

- Set these values **precisely** on the scale.

Property class Screw / nut	Tightening torque [Nm] with thread												
	M3	M4	M5	M6	M8	M10	M12	M14	M16	M18	M20	M22	M24
8.8 / 8	1.15	2.64	5.2	9.0	21.5	42.5	73.5	118	180	258	362	495	625
10.9 / 10	1.68	3.88	7.6	13.2	32.0	62.5	108	173	264	368	520	700	890
12.9 / 12	1.97	4.55	9.0	15.4	37.5	73.5	126	202	310	430	605	820	1040

Tbl-18: Tightening torques for headless screws and nuts



WITTENSTEIN alpha GmbH · Walter-Wittenstein-Straße 1 · 97999 Igersheim · Germany
Tel. +49 7931 493-12900 · info@wittenstein.de

WITTENSTEIN - one with the future

www.wittenstein-alpha.de