

TPM⁺ servo actuators

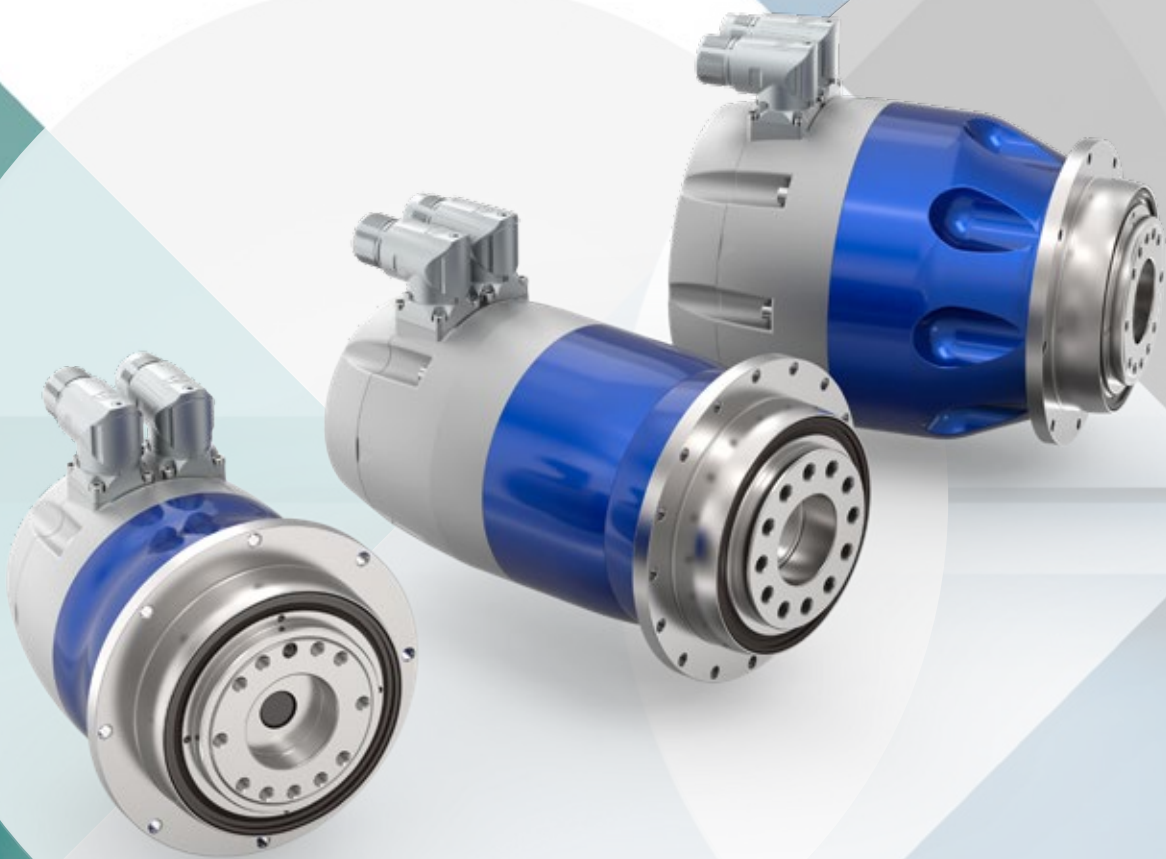

TPM+

Overview of the TPM+ product family

The TPM+ product family is convincing. With its dynamics, torque and torsional rigidity. Extremely compact, high power density and superior smooth-running operation. Combined with its practice oriented performance graduation always an economic advantage in your production.

Product declarations

Servo actuator

The TPM+ product family is above all dynamic and compact. Servo motors and gearboxes merge seamlessly into a single versatile unit. The benefit: maximum power density in a smaller footprint allows for design flexibility.

Motor

Outstanding performance: permanently activated synchronous motor with highest power density thanks to rare earth magnets, a high pole count and a high fill factor with very low cogging (pole cogging torque).

Gearbox

The planetary gearboxes offer minimal backlash while achieving a high degree of torsional and tilting rigidity. The smooth-running helical toothing guarantees silent operation.

More productive. More efficient.
More precise.

More productive ...

The benefits: A servo actuator with a low moment of inertia and an extremely rigid drive train provides for maximum precision and power. A decisive increase in productivity.

More efficient ...

Low torsional backlash, an output bearing with a high degree of tilting rigidity and integration of the gearbox pinion in the motor shaft result in: smaller motors, reduced energy consumption and lower investment costs.

More precise ...

Low levels of operating noise due to helical toothing and outstanding control properties ensure greater precision in your machines and plants. The result: genuinely economical products.

Additional features

- Various encoders and permanent magnet holding brake available.
- Direct attachment of drive components (pinion, belt pulley, indexing table) to standardized output flange.
- UL version as standard.
- Pre-assembled cables for selected servo controllers available.
- Simple commissioning thanks to special instructions for numerous servo controllers.
- Torsional backlash reduction to less than 1 arcmin possible.
- Electrical connection via time-saving bayonet couplings.
- Robust output bearing eliminates the need for additional bearing point.

TPM+ DYNAMIC

More dynamic – Shorter – Quieter

Extra productivity: Outstanding dynamics, compact dimensions and extremely smooth running. Servo actuator with two-stage gearbox designed primarily for rotary applications.

TPM+ HIGH TORQUE

Stronger – More compact – Higher torsional rigidity

The unrelenting plus: high torsional rigidity and superior power density. Two or three-stage servo actuator for heavy-duty applications.

TPM+ POWER

Stronger – Quieter – More compact

Extra power: high torque, compact dimensions. Single or two-stage servo actuator gearbox combination for linear and rotary applications.

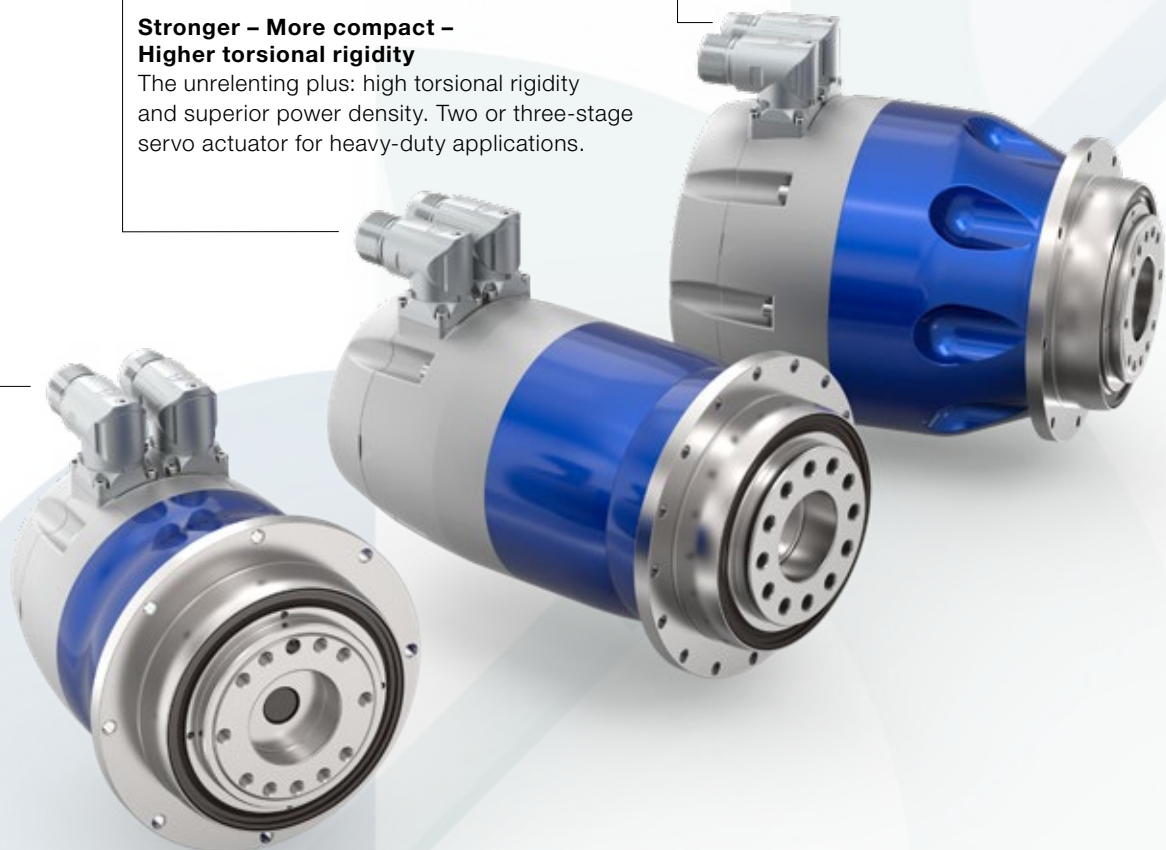

TPM⁺ DYNAMIC



Dynamic. Shorter. Quieter.

Experience extraordinary dynamics thanks to modern motor technology with high power density, a low moment of inertia and optimal torsional rigidity. Benefit from a reduced installation length: The coupling-free connection between motor and gearbox and the space-saving attachment of motor instruments make the TPM+ DYNAMIC over 50 % more compact than conventional gearbox motors. Helical-toothed precision planetary gearboxes ensure low-vibration and silent operation.

Size	Installation length in mm	Max. acceleration torque in Nm	Max. power in kW
004	from 113	up to 40	up to 1
010	from 142	up to 100	up to 1.5
025	from 153	up to 300	up to 4.7
050	from 187	up to 650	up to 10.2
110	from 268	up to 1300	up to 14.2

Application example

Whether used as an axis drive for spraying robots, a swivel drive in the production of optical media and semiconductors, in packaging machines or as a drive for changer systems in machine tools or wood processing systems, the TPM+ DYNAMIC is ideal for all robotic and automated applications.



Source: Hastamat Verpackungstechnik

TPM+ DYNAMIC 004 2-stage

			2-stage					
Ratio	i		16	21	31	61	64	91
Operating voltage	U_D	V DC	560					
Max. acceleration torque (max. 1000 cycles per hour)	T_{2B}	Nm	30	32	40	32	32	32
		in.lb	266	283	354	283	283	283
Static output torque	T_{20}	Nm	8	11	17	15	15	15
		in.lb	71	97	150	133	133	133
Brake holding torque (at 120 °C)	T_{2Br}	Nm	18	23	34	67	70	100
		in.lb	159	204	301	593	620	885
Max. speed at output	n_{2max}	rpm	375	286	194	98	94	66
Speed limit for T_{2B}	n_{2B}	rpm	313	262	189	98	94	66
Max. motor acceleration torque	T_{1max}	Nm	2	2	2	1	1	1
		in.lb	18	18	18	9	9	9
Max. motor acceleration current	I_{MaxDyn}	A_{eff}	3.2	3.2	3.2	2.4	2.4	2.4
Static motor current	I_0	A_{eff}	1.1	1.1	1.1	0.8	0.8	0.8
Max. backlash	j_t	arcmin	Standard ≤ 4 Reduced ≤ 2					
Torsional rigidity (Gearbox)	C_{t21}	Nm/arcmin	-	10	9	9	-	7
		in.lb/arcmin	-	89	80	80	-	62
Tilting rigidity	C_{2K}	Nm/arcmin	85					
		in.lb/arcmin	752					
Max. axial force ^{a)}	F_{2AMax}	N	1630					
		lb _f	367					
Max. tilting moment	M_{2KMax}	Nm	110					
		in.lb	974					
Service life ^{b)}	L_h	h	> 20000					
Weight (without brake)	m	kg	2 to 2.2					
		lb _m	4.4 to 4.9					
Ambient temperature		°C	0 to +40					
		°F	+32 to +104					
Lubrication			Lubricated for life					
Insulating material class			F					
Protection class			IP 65					
Paint			Blue metallic 250 and natural cast aluminium					
Metal bellows coupling (recommended product type – validate sizing with cymex®)			BCT-00015AAX-031.500					
Bore diameter of coupling on the application side		mm	X = 012.000 - 028.000					
Mass moment of inertia (relates to the drive)	J_1	kgcm ²	0.21	0.2	0.2	0.12	0.11	0.12
		10 ⁻³ in.lb.s ²	0.19	0.18	0.18	0.11	0.1	0.11

Please use our sizing software cymex® for a detailed sizing – www.wittenstein-cymex.com

^{a)} Refers to center of the output shaft or flange

^{b)} Please contact us to discuss application-specific service lifetimes.

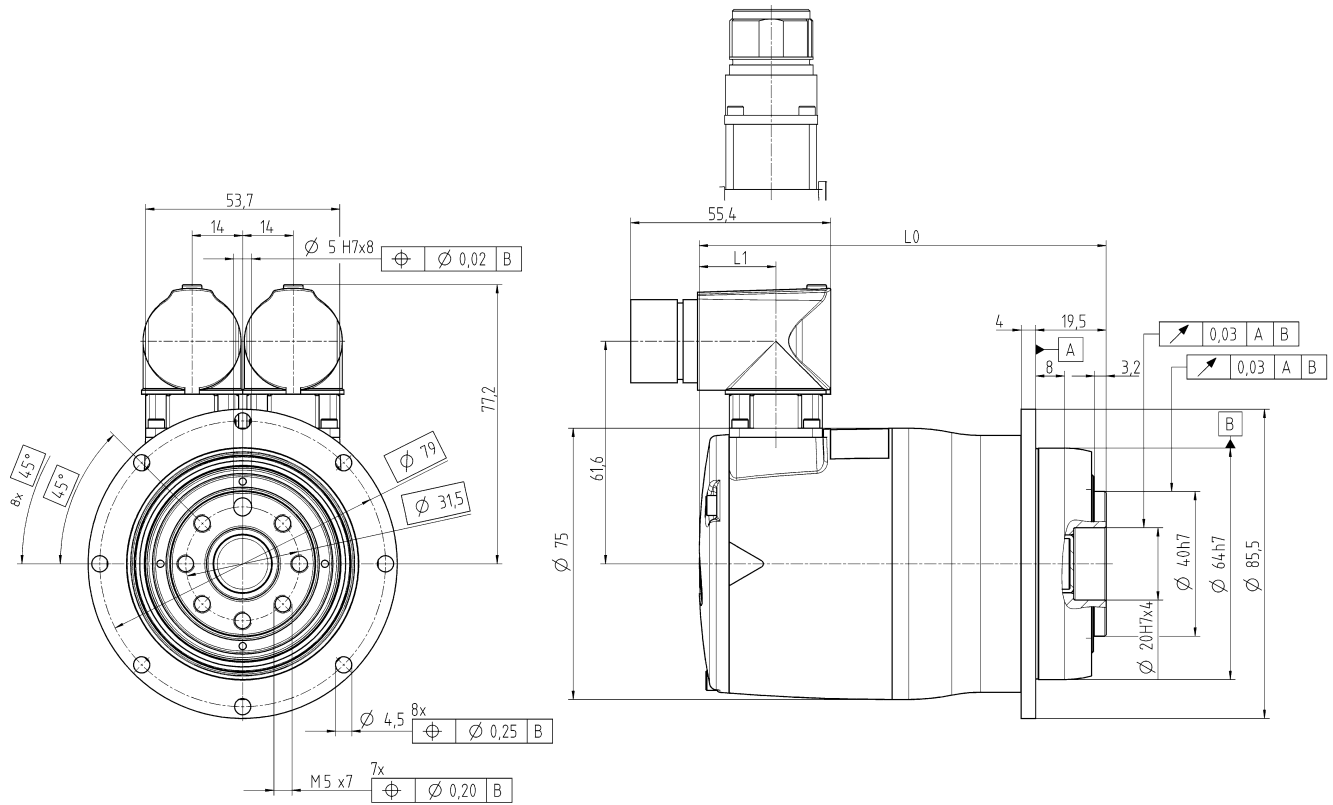

without brake

Ratio	Encoder	Length L0 in mm	Length L1 in mm
i = 16/21/31	Resolver	128	22
	HIPERFACE®	153	47
	EnDat	157	51
i = 61/64/91	Resolver	113	22
	HIPERFACE®	138	47
	EnDat	142	51

with brake

Ratio	Encoder	Length L0 in mm	Length L1 in mm
i = 16/21/31	Resolver	165	22
	HIPERFACE®	190	47
	EnDat	194	51
i = 61/64/91	Resolver	150	22
	HIPERFACE®	175	47
	EnDat	179	51

TPM+ DYNAMIC 010 2-stage

			2-stage					
Ratio	i		16	21	31	61	64	91
Operating voltage	U_D	V DC	560					
Max. acceleration torque (max. 1000 cycles per hour)	T_{2B}	Nm	57	75	100	80	80	80
		in.lb	504	664	885	708	708	708
Static output torque	T_{20}	Nm	13	18	27	29	28	35
		in.lb	115	159	239	257	248	310
Brake holding torque (at 120 °C)	T_{2Br}	Nm	18	23	34	67	70	100
		in.lb	159	204	301	593	620	885
Max. speed at output	n_{2max}	rpm	375	286	194	98	94	66
Speed limit for T_{2B}	n_{2B}	rpm	256	195	132	81	78	54
Max. motor acceleration torque	T_{1max}	Nm	3.8	3.8	3.8	1.9	1.9	1.9
		in.lb	34	34	34	17	17	17
Max. motor acceleration current	I_{MaxDyn}	A_{eff}	5.2	5.2	5.2	3	3	3
Static motor current	I_0	A_{eff}	1.3	1.3	1.3	0.9	0.9	0.9
Max. backlash	j_t	arcmin	Standard ≤ 3 Reduced ≤ 1					
Torsional rigidity (Gearbox)	C_{t21}	Nm/arcmin	-	26	24	24	-	21
		in.lb/arcmin	-	230	212	212	-	186
Tilting rigidity	C_{2K}	Nm/arcmin	225					
		in.lb/arcmin	1991					
Max. axial force ^{a)}	F_{2AMax}	N	2150					
		lb _f	484					
Max. tilting moment	M_{2KMax}	Nm	270					
		in.lb	2390					
Service life ^{b)}	L_h	h	> 20000					
Weight (without brake)	m	kg	4.3 to 4.8					
		lb _m	9.5 to 11					
Ambient temperature		°C	0 to +40					
		°F	+32 to +104					
Lubrication			Lubricated for life					
Insulating material class			F					
Protection class			IP 65					
Paint			Blue metallic 250 and natural cast aluminium					
Metal bellows coupling (recommended product type – validate sizing with cymex®)			BCT-00060AAX-050.000					
Bore diameter of coupling on the application side		mm	X = 014.000 - 035.000					
Mass moment of inertia (relates to the drive)	J_1	kgcm ²	0.32	0.32	0.32	0.17	0.17	0.17
		10 ⁻³ in.lb.s ²	0.28	0.28	0.28	0.15	0.15	0.15

Please use our sizing software cymex® for a detailed sizing – www.wittenstein-cymex.com

^{a)} Refers to center of the output shaft or flange

^{b)} Please contact us to discuss application-specific service lifetimes.

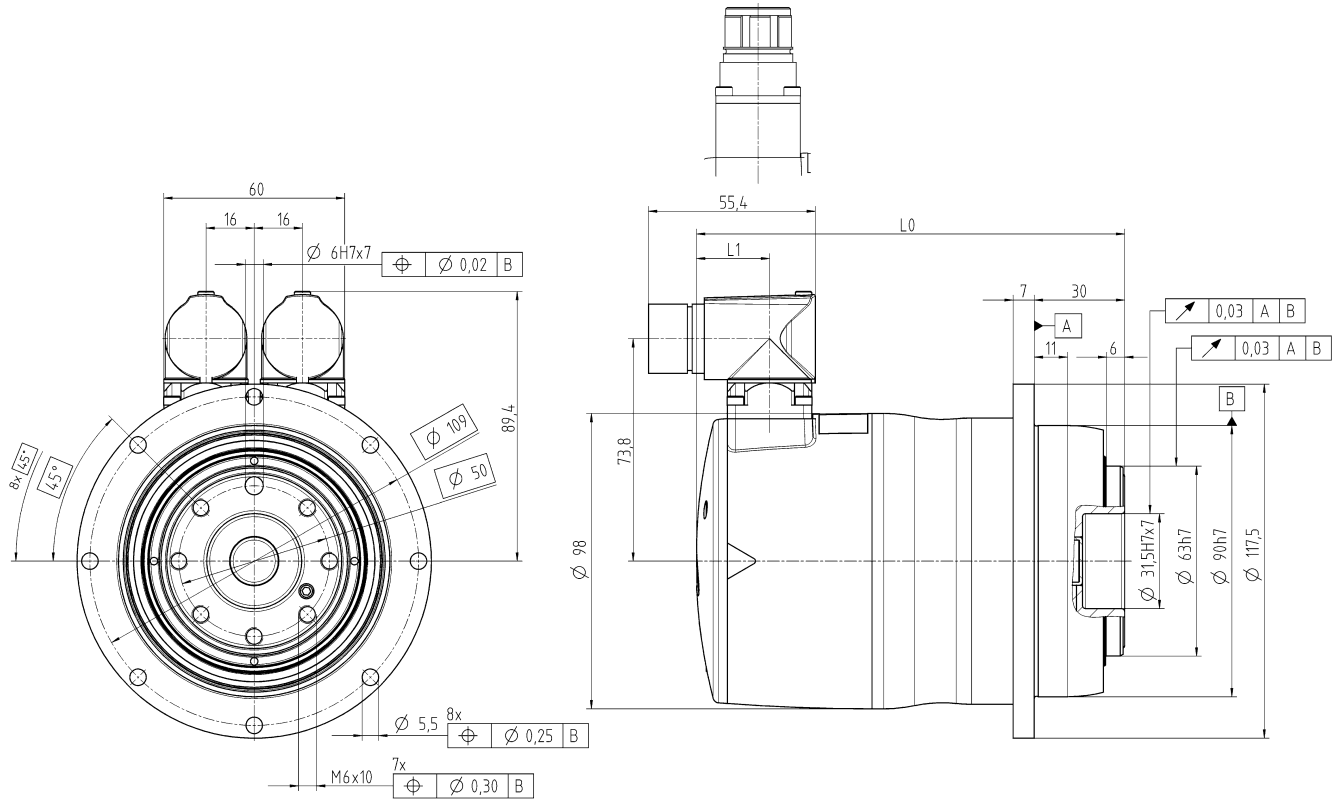

without brake

Ratio	Encoder	Length L0 in mm	Length L1 in mm
i = 16/21/31	Resolver	157	24
	HIPERFACE®	178	45
	EnDat	182	49
i = 61/64/91	Resolver	142	24
	HIPERFACE®	163	45
	EnDat	167	49

with brake

Ratio	Encoder	Length L0 in mm	Length L1 in mm
i = 16/21/31	Resolver	178	24
	HIPERFACE®	199	45
	EnDat	202	49
i = 61/64/91	Resolver	163	24
	HIPERFACE®	184	45
	EnDat	187	49

TPM+ DYNAMIC 025 2-stage

			2-stage					
Ratio	i		16	21	31	61	64	91
Operating voltage	U_D	V DC	560					
Max. acceleration torque (max. 1000 cycles per hour)	T_{2B}	Nm	182	239	300	250	250	250
		in.lb	1611	2115	2655	2213	2213	2213
Static output torque	T_{20}	Nm	74	97	146	87	83	100
		in.lb	655	859	1292	770	735	885
Brake holding torque (at 120 °C)	T_{2Br}	Nm	72	94	140	274	288	410
		in.lb	637	832	1239	2425	2549	3629
Max. speed at output	n_{2max}	rpm	375	286	194	98	94	66
Speed limit for T_{2B}	n_{2B}	rpm	244	185	125	59	56	39
Max. motor acceleration torque	T_{1max}	Nm	12.1	12.1	12.1	4.4	4.4	4.4
		in.lb	107	107	107	39	39	39
Max. motor acceleration current	I_{MaxDyn}	A_{eff}	17	17	17	6	6	6
Static motor current	I_0	A_{eff}	5.7	5.7	5.7	1.9	1.9	1.9
Max. backlash	j_t	arcmin	Standard ≤ 3 Reduced ≤ 1					
Torsional rigidity (Gearbox)	C_{t21}	Nm/arcmin	-	70	54	61	-	55
		in.lb/arcmin	-	620	478	540	-	487
Tilting rigidity	C_{2K}	Nm/arcmin	550					
		in.lb/arcmin	4868					
Max. axial force ^{a)}	F_{2AMax}	N	4150					
		lb _f	934					
Max. tilting moment	M_{2KMax}	Nm	440					
		in.lb	3894					
Service life ^{b)}	L_h	h	> 20000					
Weight (without brake)	m	kg	7.1 to 8.5					
		lb _m	16 to 19					
Ambient temperature		°C	0 to +40					
		°F	+32 to +104					
Lubrication			Lubricated for life					
Insulating material class			F					
Protection class			IP 65					
Paint			Blue metallic 250 and natural cast aluminium					
Metal bellows coupling (recommended product type – validate sizing with cymex®)			BCT-00150AAX-063.000					
Bore diameter of coupling on the application side		mm	X = 019.000 - 042.000					
Mass moment of inertia (relates to the drive)	J_1	kgcm ²	2.16	2.16	2.17	0.77	0.76	0.76
		10 ⁻³ in.lb.s ²	1.9	1.9	1.9	0.68	0.67	0.67

Please use our sizing software cymex® for a detailed sizing – www.wittenstein-cymex.com

^{a)} Refers to center of the output shaft or flange

^{b)} Please contact us to discuss application-specific service lifetimes.

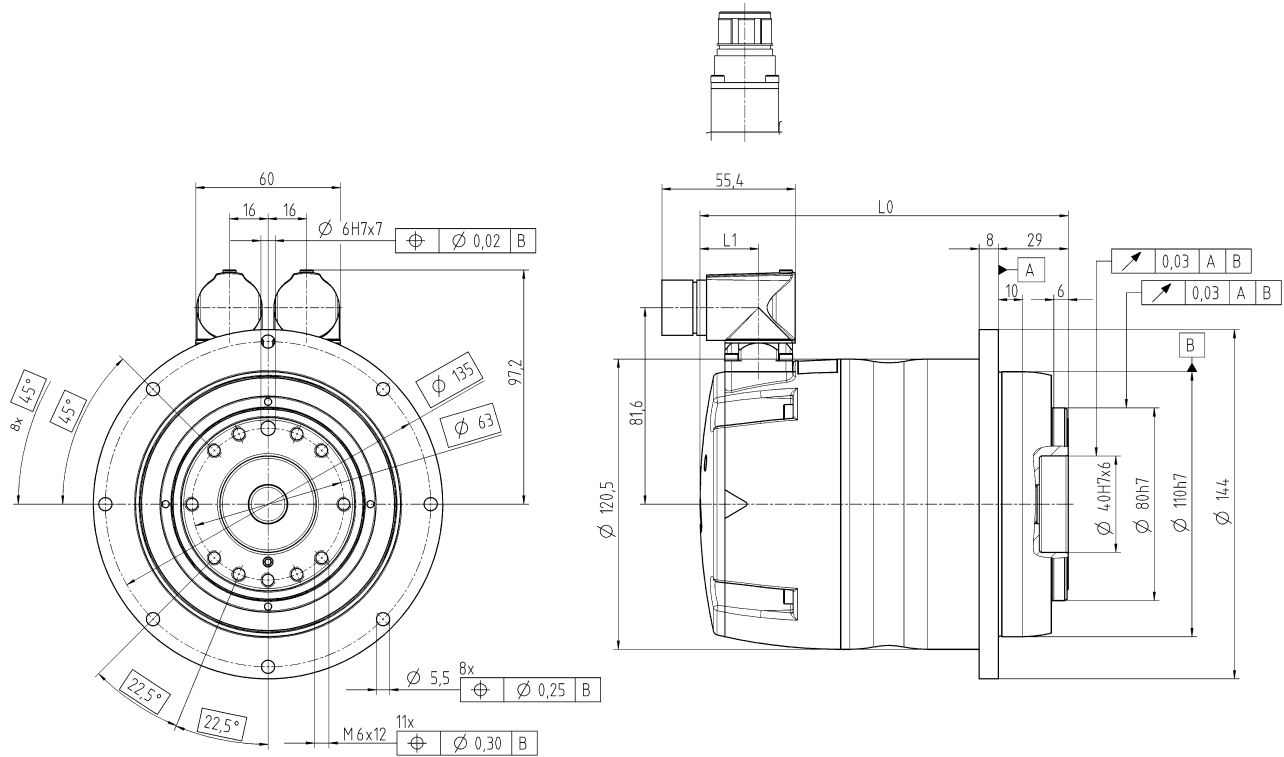

without brake

Ratio	Encoder	Length L0 in mm	Length L1 in mm
i = 16/21/31	Resolver	183	24
	HIPERFACE®	204	45
	EnDat	208	49
i = 61/64/91	Resolver	153	24
	HIPERFACE®	174	45
	EnDat	178	49

with brake

Ratio	Encoder	Length L0 in mm	Length L1 in mm
i = 16/21/31	Resolver	202	24
	HIPERFACE®	223	45
	EnDat	227	49
i = 61/64/91	Resolver	172	24
	HIPERFACE®	193	45
	EnDat	197	49

TPM+ DYNAMIC 050 2-stage

			2-stage					
Ratio	i		16	21	31	61	64	91
Operating voltage	U_D	V DC	560					
Max. acceleration torque (max. 1000 cycles per hour)	T_{2B}	Nm	435	500	650	447	469	500
		in.lb	3850	4425	5753	3956	4151	4425
Static output torque	T_{20}	Nm	185	220	370	173	166	220
		in.lb	1637	1947	3275	1531	1469	1947
Brake holding torque (at 120 °C)	T_{2Br}	Nm	208	273	403	793	832	1183
		in.lb	1841	2416	3567	7019	7364	10470
Max. speed at output	n_{2max}	rpm	312	238	161	82	78	55
Speed limit for T_{2B}	n_{2B}	rpm	225	171	116	59	56	39
Max. motor acceleration torque	T_{1max}	Nm	28.9	28.9	28.9	7.8	7.8	7.8
		in.lb	256	256	256	69	69	69
Max. motor acceleration current	I_{MaxDyn}	A_{eff}	40	40	40	12	12	12
Static motor current	I_0	A_{eff}	13.7	13.7	13.7	3.8	3.8	3.8
Max. backlash	j_t	arcmin	Standard ≤ 3 Reduced ≤ 1					
Torsional rigidity (Gearbox)	C_{t21}	Nm/arcmin	-	145	130	123	-	100
		in.lb/arcmin	-	1283	1151	1089	-	885
Tilting rigidity	C_{2K}	Nm/arcmin	560					
		in.lb/arcmin	4956					
Max. axial force ^{a)}	F_{2AMax}	N	6130					
		lb _f	1379					
Max. tilting moment	M_{2KMax}	Nm	1335					
		in.lb	11816					
Service life ^{b)}	L_h	h	> 20000					
Weight (without brake)	m	kg	14.7 to 18.5					
		lb _m	32 to 41					
Ambient temperature		°C	0 to +40					
		°F	+32 to +104					
Lubrication			Lubricated for life					
Insulating material class			F					
Protection class			IP 65					
Paint			Blue metallic 250 and natural cast aluminium					
Metal bellows coupling (recommended product type – validate sizing with cymex®)			BCT-00300AAX-080.000					
Bore diameter of coupling on the application side		mm	X = 024.000 - 060.000					
Mass moment of inertia (relates to the drive)	J_1	kgcm ²	9.07	9.07	8.94	2.51	2.49	2.49
		10 ⁻³ in.lb.s ²	8	8	7.9	2.2	2.2	2.2

Please use our sizing software cymex® for a detailed sizing – www.wittenstein-cymex.com

^{a)} Refers to center of the output shaft or flange

^{b)} Please contact us to discuss application-specific service lifetimes.

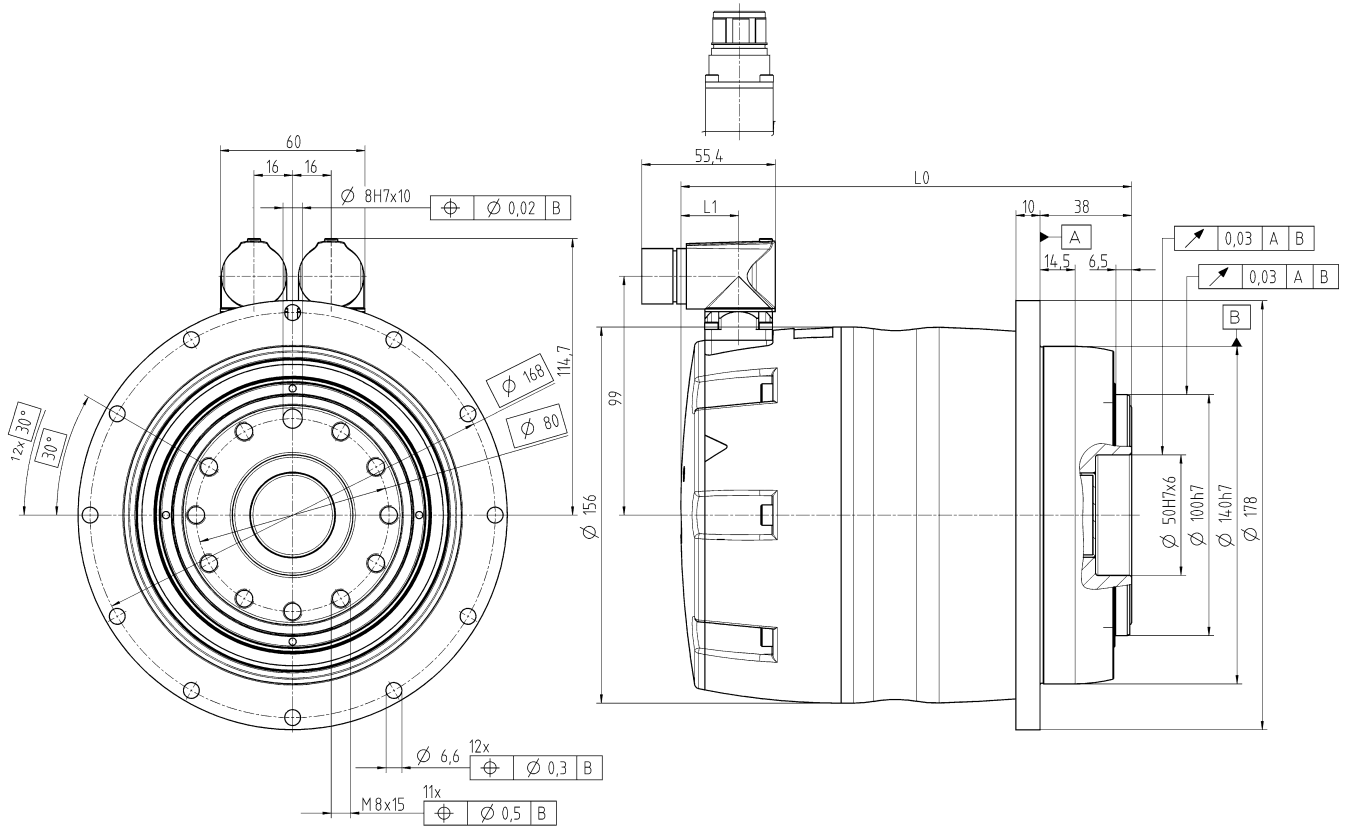

without brake

Ratio	Encoder	Length L0 in mm	Length L1 in mm
i = 16/21/31	Resolver	232	24
	HIPERFACE®	253	45
	EnDat	257	49
i = 61/64/91	Resolver	187	24
	HIPERFACE®	208	45
	EnDat	212	49

with brake

Ratio	Encoder	Length L0 in mm	Length L1 in mm
i = 16/21/31	Resolver	256	24
	HIPERFACE®	278	45
	EnDat	281	49
i = 61/64/91	Resolver	211	24
	HIPERFACE®	233	45
	EnDat	236	49

TPM+ DYNAMIC 110 2-stage

			2-stage					
Ratio	i		16	21	31	61	64	91
Operating voltage	U_D	V DC	560					
Max. acceleration torque (max. 1000 cycles per hour)	T_{2B}	Nm	660	867	1279	1300	1300	1300
		in.lb	5842	7674	11320	11506	11506	11506
Static output torque	T_{20}	Nm	208	278	419	700	700	700
		in.lb	1841	2461	3708	6196	6196	6196
Brake holding torque (at 120 °C)	T_{2Br}	Nm	208	273	403	793	832	1183
		in.lb	1841	2416	3567	7019	7364	10470
Max. speed at output	n_{2max}	rpm	312	238	161	82	78	55
Speed limit for T_{2B}	n_{2B}	rpm	206	157	106	59	56	39
Max. motor acceleration torque	T_{1max}	Nm	43.9	43.9	43.9	28.9	28.9	28.9
		in.lb	389	389	389	256	256	256
Max. motor acceleration current	I_{MaxDyn}	A_{eff}	70	70	70	40	40	40
Static motor current	I_0	A_{eff}	16.7	16.7	16.7	13.7	13.7	13.7
Max. backlash	j_t	arcmin	Standard ≤ 3 Reduced ≤ 1					
Torsional rigidity (Gearbox)	C_{t21}	Nm/arcmin	-	465	440	415	-	360
		in.lb/arcmin	-	4116	3894	3673	-	3186
Tilting rigidity	C_{2K}	Nm/arcmin	1452					
		in.lb/arcmin	12851					
Max. axial force ^{a)}	F_{2AMax}	N	10050					
		lb _f	2261					
Max. tilting moment	M_{2KMax}	Nm	3280					
		in.lb	29031					
Service life ^{b)}	L_h	h	> 20000					
Weight (without brake)	m	kg	35.9 to 37.1					
		lb _m	79 to 82					
Ambient temperature		°C	0 to +40					
		°F	+32 to +104					
Lubrication			Lubricated for life					
Insulating material class			F					
Protection class			IP 65					
Paint			Blue metallic 250 and natural cast aluminium					
Metal bellows coupling (recommended product type – validate sizing with cymex®)			BCT-01500AAX-125.000					
Bore diameter of coupling on the application side		mm	X = 050.000 - 080.000					
Mass moment of inertia (relates to the drive)	J_1	kgcm ²	13.14	13.14	12.84	8.89	8.83	8.83
		10 ⁻³ in.lb.s ²	12	12	11	7.9	7.8	7.8

Please use our sizing software cymex® for a detailed sizing – www.wittenstein-cymex.com

^{a)} Refers to center of the output shaft or flange

^{b)} Please contact us to discuss application-specific service lifetimes.

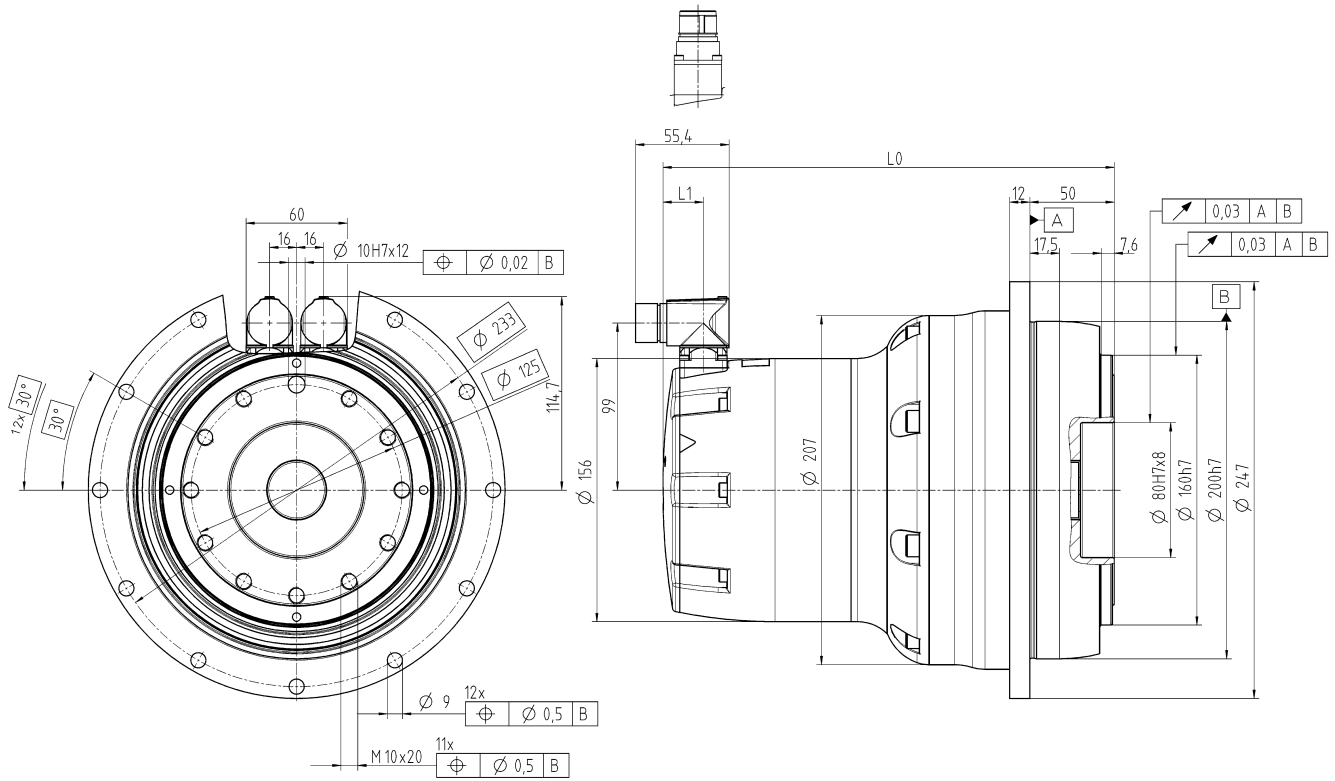

without brake

Ratio	Encoder	Length L0 in mm	Length L1 in mm
i = 16/21/31	Resolver	283	24
	HIPERFACE®	304	45
	EnDat	308	49
i = 61/64/91	Resolver	268	24
	HIPERFACE®	289	45
	EnDat	293	49

with brake

Ratio	Encoder	Length L0 in mm	Length L1 in mm
i = 16/21/31	Resolver	307	24
	HIPERFACE®	328	45
	EnDat	332	49
i = 61/64/91	Resolver	292	24
	HIPERFACE®	313	45
	EnDat	317	49

TPM⁺ HIGH TORQUE

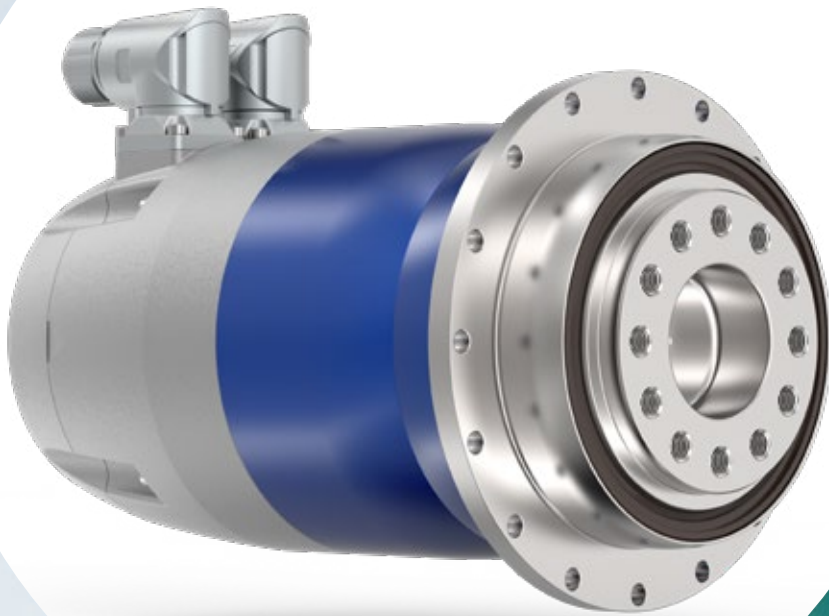

Stronger. More compact. Higher torsional rigidity.

This servo actuator brings you even further: with 50 % more torque and improved performance. Even better power transmission due to the more rigid drive train offers higher acceleration and shorter cycle times. Effectiveness from which you benefit. An additional planet in the gearbox significantly increases the torsional rigidity of the particularly short and light servo actuator. The coupling-free integration of motor and gearbox and the efficient attachment of motor instruments is the formula for success.

Size	Installation length in mm	Max. acceleration torque in Nm	Max. power in kW
010	from 183	up to 230	up to 4.5
025	from 219	up to 530	up to 9.8
050	from 279	up to 950	up to 15.6

Application example

Thanks to the TPM+ HIGH TORQUE, machine tools and swivel axes become significantly more productive. The high torsional rigidity and the ample torque reserve in the case of disturbing forces ensure extremely stable drive control. The reliable servo actuator therefore guarantees dynamics and precision for your (heavy-duty) tasks.



TPM+ HIGH TORQUE 010 2-/3-stage

			2-stage				3-stage			
Ratio	i		22	27,5	38,5	55	88	110	154	220
Operating voltage	U_D	VDC	560							
Max. acceleration torque (max. 1000 cycles per hour)	T_{2B}	Nm	230	230	230	230	230	230	230	230
		in.lb	2036	2036	2036	2036	2036	2036	2036	2036
Static output torque	T_{20}	Nm	79	99	139	110	180	180	180	180
		in.lb	699	876	1230	974	1593	1593	1593	1593
Brake holding torque (at 120 °C)	T_{2Br}	Nm	99	124	173	248	396	495	277	396
		in.lb	876	1097	1531	2195	3505	4381	2452	3505
Max. speed at output	n_{2max}	rpm	220	176	126	88	55	44	31	22
Speed limit for T_{2B}	n_{2B}	rpm	187	163	126	88	55	44	31	22
Max. motor acceleration torque	T_{1max}	Nm	12	12	12	12	12	12	4.4	4.4
		in.lb	106	106	106	106	106	106	39	39
Max. motor acceleration current	I_{MaxDyn}	A_{eff}	17	17	17	17	17	17	6	6
Static motor current	I_0	A_{eff}	5	5	5	5	5	5	1.9	1.9
Max. backlash	j_t	arcmin	≤ 1							
Torsional rigidity (Gearbox)	C_{t21}	Nm/arcmin	43	43	43	42	42	42	42	42
		in.lb/arcmin	381	381	381	372	372	372	372	372
Tilting rigidity	C_{2K}	Nm/arcmin	225							
		in.lb/arcmin	1991							
Max. axial force ^{a)}	F_{2AMax}	N	2150							
		lb _f	484							
Max. tilting moment	M_{2KMax}	Nm	400							
		in.lb	3540							
Service life ^{b)}	L_h	h	> 20000							
Weight (without brake)	m	kg	6.5 to 8							
		lb _m	14 to 18							
Ambient temperature		°C	0 to +40							
		°F	+32 to +104							
Lubrication			Lubricated for life							
Insulating material class			F							
Protection class			IP 65							
Paint			Blue metallic 250 and natural cast aluminium							
Metal bellows coupling (recommended product type – validate sizing with cymex®)			BCT-00150AAX-050.00A							
Bore diameter of coupling on the application side		mm	X = 016.000 - 038.000							
Mass moment of inertia (relates to the drive)	J_1	kgcm ²	2.06	2.03	2.01	1.99	2.01	2	0.68	0.67
		10 ⁻³ in.lb.s ²	1.8	1.8	1.8	1.8	1.8	1.8	0.6	0.59

Please use our sizing software cymex® for a detailed sizing – www.wittenstein-cymex.com

^{a)} Refers to center of the output shaft or flange

^{b)} Please contact us to discuss application-specific service lifetimes.

TPM+ HIGH TORQUE 025 2-/3-stage

			2-stage				3-stage				
Ratio	i		22	27,5	38,5	55	66	88	110	154	220
Operating voltage	U_D	VDC	560								
Max. acceleration torque (max. 1000 cycles per hour)	T_{2B}	Nm	530	530	530	530	480	480	480	480	480
		in.lb	4691	4691	4691	4691	4248	4248	4248	4248	4248
Static output torque	T_{20}	Nm	232	291	375	375	260	260	260	260	260
		in.lb	2053	2576	3319	3319	2301	2301	2301	2301	2301
Brake holding torque (at 120 °C)	T_{2Br}	Nm	286	358	500	715	297	396	495	693	990
		in.lb	2531	3169	4425	6328	2629	3505	4381	6134	8762
Max. speed at output	n_{2max}	rpm	220	176	126	88	73	55	44	31	22
Speed limit for T_{2B}	n_{2B}	rpm	177	155	122	88	70	55	44	31	22
Max. motor acceleration torque	T_{1max}	Nm	28.9	28.9	28.9	28.9	12	12	12	12	12
		in.lb	256	256	256	256	106	106	106	106	106
Max. motor acceleration current	I_{MaxDyn}	A_{eff}	40	40	40	40	17	17	17	17	17
Static motor current	I_0	A_{eff}	13.1	13.1	13.1	13.1	5.8	5.8	5.8	5.8	5.8
Max. backlash	j_t	arcmin	≤ 1								
Torsional rigidity (Gearbox)	C_{i21}	Nm/arcmin	105	105	105	100	95	95	95	95	95
		in.lb/arcmin	929	929	929	885	841	841	841	841	841
Tilting rigidity	C_{2K}	Nm/arcmin	550								
		in.lb/arcmin	4868								
Max. axial force ^{a)}	F_{2AMax}	N	4150								
		lb _f	934								
Max. tilting moment	M_{2KMax}	Nm	550								
		in.lb	4868								
Service life ^{b)}	L_h	h	> 20000								
Weight (without brake)	m	kg	10 to 14.8								
		lb _m	22 to 33								
Ambient temperature		°C	0 to +40								
		°F	+32 to +104								
Lubrication			Lubricated for life								
Insulating material class			F								
Protection class			IP 65								
Paint			Blue metallic 250 and natural cast aluminium								
Metal bellows coupling (recommended product type – validate sizing with cymex®)			BCT-00300AAX-063.00A								
Bore diameter of coupling on the application side		mm	X = 030.000 - 056.000								
Mass moment of inertia (relates to the drive)	J_1	kgcm ²	9.01	8.83	8.74	8.69	2.03	1.96	1.93	1.91	1.89
		10 ⁻³ in.lb.s ²	8	7.8	7.7	7.7	1.8	1.7	1.7	1.7	1.7

Please use our sizing software cymex® for a detailed sizing – www.wittenstein-cymex.com

^{a)} Refers to center of the output shaft or flange

^{b)} Please contact us to discuss application-specific service lifetimes.

**Ratio
22 to 55**

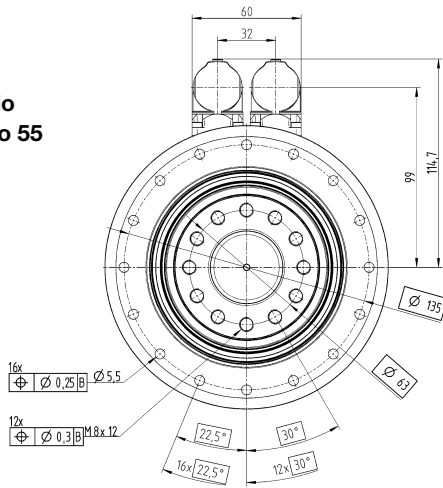

**Ratio
66 to 220**

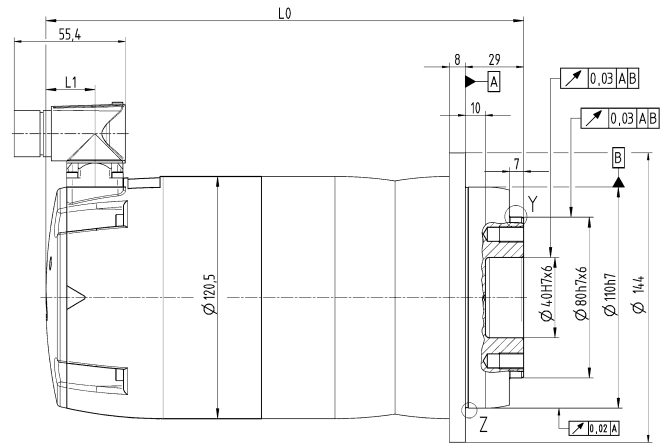
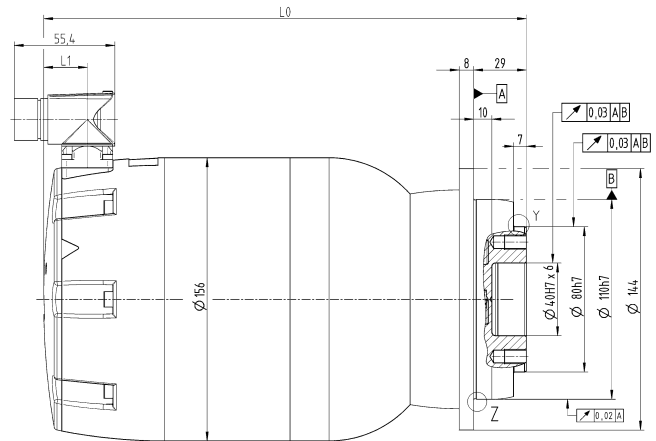
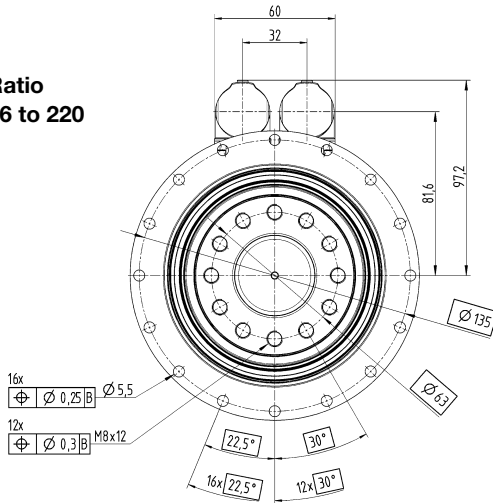

without brake

Ratio	Encoder	Length L0 in mm	Length L1 in mm
i = 22/27.5/38.5/55	Resolver	242	24
	HIPERFACE®	263	45
	EnDat	267	49
i = 66/88/110/154/220	Resolver	219	24
	HIPERFACE®	240	45
	EnDat	244	49

with brake

Ratio	Encoder	Length L0 in mm	Length L1 in mm
i = 22/27.5/38.5/55	Resolver	266	24
	HIPERFACE®	287	45
	EnDat	291	49
i = 66/88/110/154/220	Resolver	238	24
	HIPERFACE®	259	45
	EnDat	263	49

TPM+

TPM+ HIGH TORQUE 050 2-/3-stage

			2-stage				3-stage				
Ratio	i		22	27.5	38.5	55	66	88	110	154	220
Operating voltage	U_D	VDC	560								
Max. acceleration torque (max. 1000 cycles per hour)	T_{2B}	Nm	950	950	950	950	950	950	950	950	950
		in.lb	8408	8408	8408	8408	8408	8408	8408	8408	8408
Static output torque	T_{20}	Nm	406	513	650	675	675	675	675	675	675
		in.lb	3593	4540	5753	5974	5974	5974	5974	5974	5974
Brake holding torque (at 120 °C)	T_{2Br}	Nm	506	632	886	1265	858	1144	1430	2002	2375
		in.lb	4479	5594	7842	11196	7594	10125	12657	17719	21021
Max. speed at output	n_{2max}	rpm	205	164	117	82	73	55	44	31	22
Speed limit for T_{2B}	n_{2B}	rpm	156	136	108	82	69	55	44	31	22
Max. motor acceleration torque	T_{1max}	Nm	56.6	56.6	56.6	56.6	28.9	28.9	28.9	28.9	28.9
		in.lb	501	501	501	501	256	256	256	256	256
Max. motor acceleration current	I_{MaxDyn}	A_{eff}	63.5	63.5	63.5	63.5	40	40	40	40	40
Static motor current	I_0	A_{eff}	17.9	17.9	17.9	17.9	12.6	12.6	12.6	12.6	12.6
Max. backlash	j_t	arcmin	≤ 1								
Torsional rigidity (Gearbox)	C_{i21}	Nm/arcmin	220	220	220	220	205	205	205	205	205
		in.lb/arcmin	1947	1947	1947	1947	1814	1814	1814	1814	1814
Tilting rigidity	C_{2K}	Nm/arcmin	560								
		in.lb/arcmin	4956								
Max. axial force ^{a)}	F_{2AMax}	N	6130								
		lb _f	1379								
Max. tilting moment	M_{2KMax}	Nm	1335								
		in.lb	11816								
Service life ^{b)}	L_h	h	> 20000								
Weight (without brake)	m	kg	21.8 to 25.3								
		lb _m	48 to 56								
Ambient temperature		°C	0 to +40								
		°F	+32 to +104								
Lubrication			Lubricated for life								
Insulating material class			F								
Protection class			IP 65								
Paint			Blue metallic 250 and natural cast aluminium								
Metal bellows coupling (recommended product type – validate sizing with cymex®)			BCT-00300AAX-080.00A								
Bore diameter of coupling on the application side		mm	X = 045.000 - 056.000								
Mass moment of inertia (relates to the drive)	J_1	kgcm ²	23.8	23.35	22.99	22.81	9.23	9.04	8.84	8.74	8.69
		10 ⁻³ in.lb.s ²	21	21	20	20	8.2	8	7.8	7.7	7.7

Please use our sizing software cymex® for a detailed sizing – www.wittenstein-cymex.com

^{a)} Refers to center of the output shaft or flange

^{b)} Please contact us to discuss application-specific service lifetimes.

**Ratio
22 to 55**

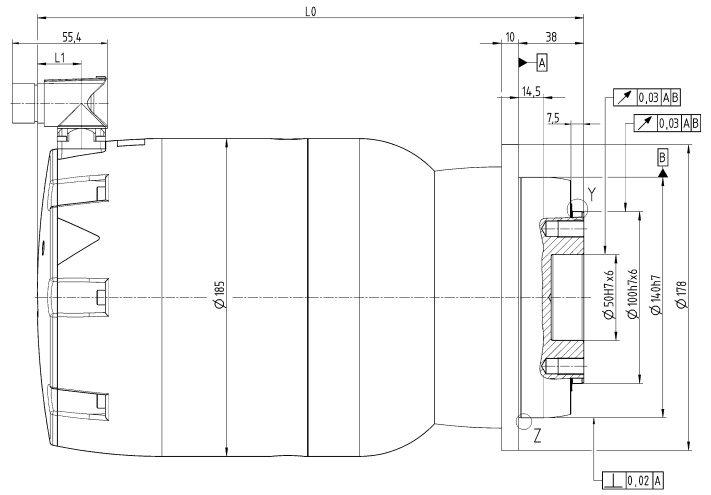
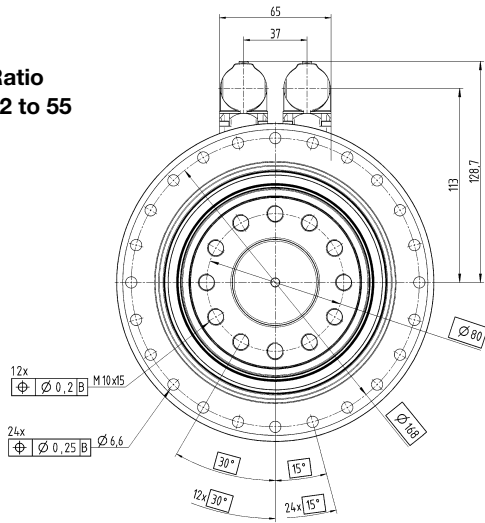

**Ratio
66 to 220**

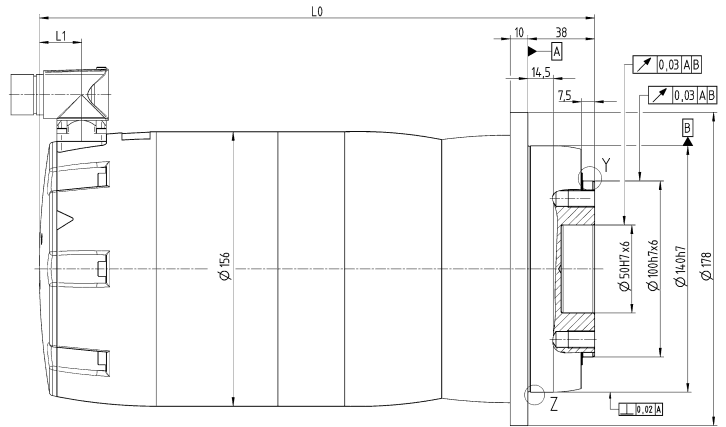
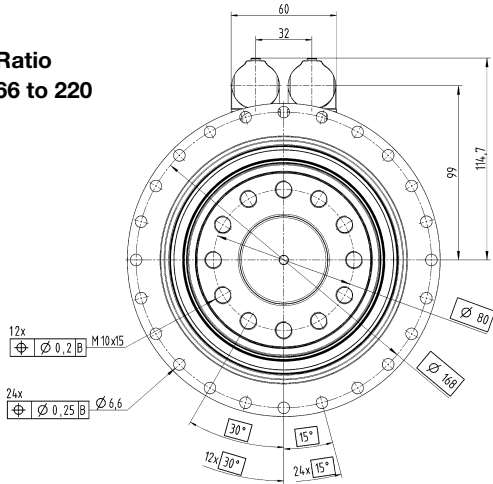

without brake

Ratio	Encoder	Length L0 in mm	Length L1 in mm
i = 22/27.5/38.5/55	Resolver	279	26
	HIPERFACE®	304	50
	EnDat	304	50
i = 66/88/110/154/220	Resolver	292	24
	HIPERFACE®	313	45
	EnDat	317	49

with brake

Ratio	Encoder	Length L0 in mm	Length L1 in mm
i = 22/27.5/38.5/55	Resolver	319	26
	HIPERFACE®	344	50
	EnDat	344	50
i = 66/88/110/154/220	Resolver	316	24
	HIPERFACE®	337	45
	EnDat	341	49

TPM⁺ POWER



Stronger. More compact. Quieter.

Generate more power: More torque, high capability. A perfect combination of motors and efficient planetary gearboxes makes light work of even the most difficult motion applications. 40 % more compact due to coupling-free connection of motor and gearbox and efficient attachment of motor instruments. Shorter installation length for greater flexibility when mounting. Helical-toothed precision planetary gearboxes for extremely quiet and low-vibration operation reduce operating noise to very low levels.

Size	Installation length in mm	Max. acceleration torque in Nm	Max. power in kW
004	from 149	up to 50	up to 1.4
010	from 175	up to 130	up to 4.7
025	from 197	up to 380	up to 10.6
050	from 236	up to 750	up to 16.5

TPM+

Application example

The compact TPM+ POWER drive unit easily copes with highly dynamic linear applications with rack and pinions or ball screws as well as in rotary movements with high masses and disturbing forces.



Source: Schmale Maschinenbau GmbH

TPM+ POWER 004 1-stage

			1-stage			
Ratio	i		4	5	7	10
Operating voltage	U_D	V DC	560			
Max. acceleration torque (max. 1000 cycles per hour)	T_{2B}	Nm	15	18	26	26
		in.lb	133	159	230	230
Static output torque	T_{20}	Nm	4	6	8	12
		in.lb	35	53	71	106
Brake holding torque (at 120 °C)	T_{2Br}	Nm	4	6	8	11
		in.lb	35	53	71	97
Max. speed at output	n_{2max}	rpm	1500	1200	857	600
Speed limit for T_{2B}	n_{2B}	rpm	1040	830	590	460
Max. motor acceleration torque	T_{1max}	Nm	3.8	3.8	3.8	3.8
		in.lb	34	34	34	34
Max. motor acceleration current	I_{MaxDyn}	A_{eff}	5.2	5.2	5.2	5.2
Static motor current	I_0	A_{eff}	1.6	1.6	1.6	1.6
Max. backlash	j_t	arcmin	Standard ≤ 4 Reduced ≤ 2			
Torsional rigidity (Gearbox)	C_{i21}	Nm/arcmin	12	12	11	8
		in.lb/arcmin	106	106	97	71
Tilting rigidity	C_{2K}	Nm/arcmin	85			
		in.lb/arcmin	752			
Max. axial force ^{a)}	F_{2AMax}	N	1630			
		lb _f	367			
Max. tilting moment	M_{2KMax}	Nm	110			
		in.lb	974			
Service life ^{b)}	L_h	h	> 20000			
Weight (without brake)	m	kg	3.6			
		lb _m	8			
Ambient temperature		°C	0 to +40			
		°F	+32 to +104			
Lubrication			Lubricated for life			
Insulating material class			F			
Protection class			IP 65			
Paint			Blue metallic 250 and natural cast aluminium			
Metal bellows coupling (recommended product type – validate sizing with cymex®)			BCT-00015AAX-031.500			
Bore diameter of coupling on the application side		mm	X = 012.000 - 028.000			
Mass moment of inertia (relates to the drive)	J_1	kgcm ²	0.39	0.36	0.33	0.31
		10 ⁻³ in.lb.s ²	0.35	0.32	0.29	0.27

Please use our sizing software cymex® for a detailed sizing – www.wittenstein-cymex.com

^{a)} Refers to center of the output shaft or flange

^{b)} Please contact us to discuss application-specific service lifetimes.

TPM+ POWER 004 2-stage

			2-stage								
Ratio	i		16	20	25	28	35	40	50	70	100
Operating voltage	U_D	VDC	560								
Max. acceleration torque (max. 1000 cycles per hour)	T_{2B}	Nm	50	50	50	50	50	50	50	50	35
		in.lb	443	443	443	443	443	443	443	443	310
Static output torque	T_{20}	Nm	18	23	28	32	40	24	30	40	18
		in.lb	159	204	248	283	354	212	266	354	159
Brake holding torque (at 120 °C)	T_{2Br}	Nm	18	22	28	31	38	44	55	77	110
		in.lb	159	195	248	274	336	389	487	682	974
Max. speed at output	n_{2max}	rpm	375	300	240	214	171	150	120	86	60
Speed limit for T_{2B}	n_{2B}	rpm	260	230	200	185	158	144	120	86	60
Max. motor acceleration torque	T_{1max}	Nm	3.8	3.8	3.8	3.8	3.8	1.9	1.9	1.9	1.9
		in.lb	34	34	34	34	34	17	17	17	17
Max. motor acceleration current	I_{MaxDyn}	A_{eff}	5.2	5.2	5.2	5.2	5.2	3	3	3	3
Static motor current	I_0	A_{eff}	1.6	1.6	1.6	1.6	1.6	1	1	1	1
Max. backlash	j_t	arcmin	Standard ≤ 4 Reduced ≤ 2								
Torsional rigidity (Gearbox)	C_{i21}	Nm/arcmin	12	12	12	12	12	11	12	11	8
		in.lb/arcmin	106	106	106	106	106	97	106	97	71
Tilting rigidity	C_{2K}	Nm/arcmin	85								
		in.lb/arcmin	752								
Max. axial force ^{a)}	F_{2AMax}	N	1630								
		lb _f	367								
Max. tilting moment	M_{2KMax}	Nm	110								
		in.lb	974								
Service life ^{b)}	L_h	h	> 20000								
Weight (without brake)	m	kg	3.3 to 3.7								
		lb _m	7.3 to 8.2								
Ambient temperature		°C	0 to +40								
		°F	+32 to +104								
Lubrication			Lubricated for life								
Insulating material class			F								
Protection class			IP 65								
Paint			Blue metallic 250 and natural cast aluminium								
Metal bellows coupling (recommended product type – validate sizing with cymex®)			BCT-00015AAX-031.500								
Bore diameter of coupling on the application side		mm	X = 012.000 - 028.000								
Mass moment of inertia (relates to the drive)	J_1	kgcm ²	0.32	0.31	0.31	0.31	0.31	0.16	0.16	0.16	0.16
		10 ⁻³ in.lb.s ²	0.28	0.27	0.27	0.27	0.27	0.14	0.14	0.14	0.14

Please use our sizing software cymex® for a detailed sizing – www.wittenstein-cymex.com

^{a)} Refers to center of the output shaft or flange

^{b)} Please contact us to discuss application-specific service lifetimes.

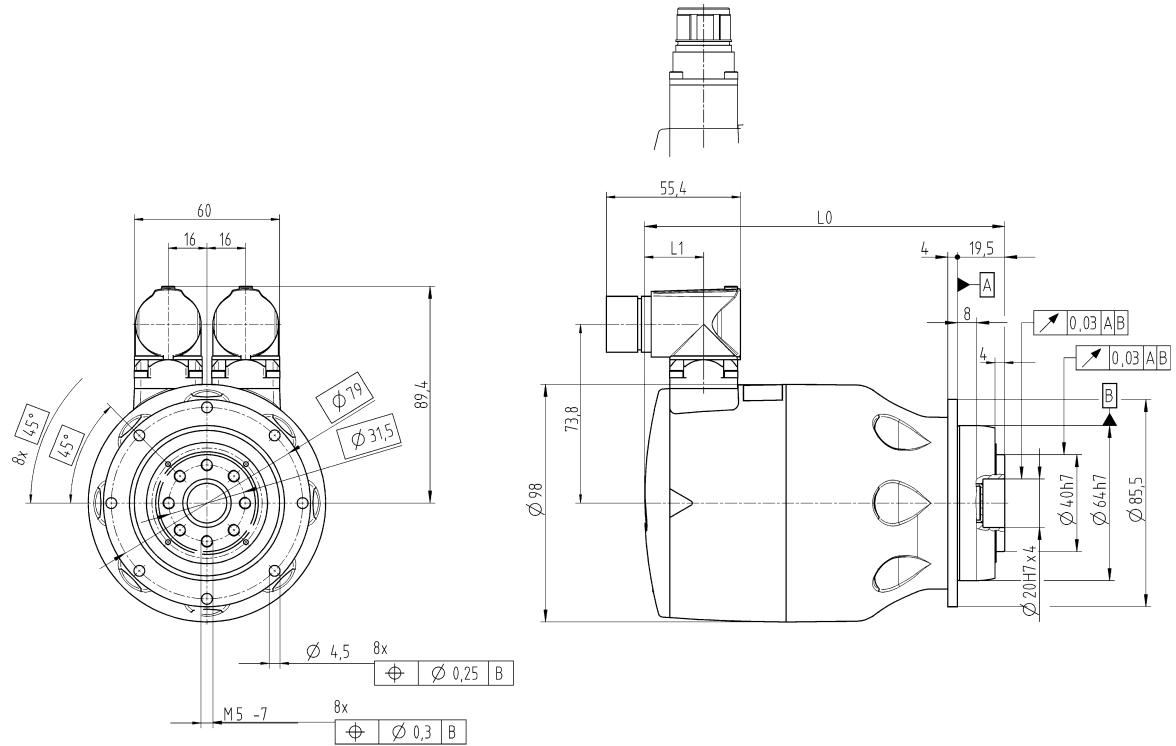

without brake

Ratio	Encoder	Length L0 in mm	Length L1 in mm
i = 16/20/25/28/35	Resolver	164	24
	HIPERFACE®	185	45
	EnDat	189	49
i = 40/50/70/100	Resolver	149	24
	HIPERFACE®	170	45
	EnDat	174	49

with brake

Ratio	Encoder	Length L0 in mm	Length L1 in mm
i = 16/20/25/28/35	Resolver	184	24
	HIPERFACE®	205	45
	EnDat	209	49
i = 40/50/70/100	Resolver	169	24
	HIPERFACE®	190	45
	EnDat	194	49

TPM+

TPM+ POWER 010 1-stage

			1-stage			
Ratio	i		4	5	7	10
Operating voltage	U_D	VDC	560			
Max. acceleration torque (max. 1000 cycles per hour)	T_{2B}	Nm	44	56	80	85
		in.lb	389	496	708	752
Static output torque	T_{20}	Nm	14	18	27	40
		in.lb	124	159	239	354
Brake holding torque (at 120 °C)	T_{2Br}	Nm	18	22	32	45
		in.lb	159	195	283	398
Max. speed at output	n_{2max}	rpm	1500	1200	857	600
Speed limit for T_{2B}	n_{2B}	rpm	980	780	560	440
Max. motor acceleration torque	T_{1max}	Nm	12.1	12.1	12.1	12.1
		in.lb	107	107	107	107
Max. motor acceleration current	I_{MaxDyn}	A_{eff}	17	17	17	17
Static motor current	I_0	A_{eff}	5.4	5.4	5.4	5.4
Max. backlash	j_t	arcmin	Standard ≤ 3 Reduced ≤ 1			
Torsional rigidity (Gearbox)	C_{i21}	Nm/arcmin	32	33	30	23
		in.lb/arcmin	283	292	266	204
Tilting rigidity	C_{2K}	Nm/arcmin	225			
		in.lb/arcmin	1991			
Max. axial force ^{a)}	F_{2AMax}	N	2150			
		lb _f	484			
Max. tilting moment	M_{2KMax}	Nm	270			
		in.lb	2390			
Service life ^{b)}	L_h	h	> 20000			
Weight (without brake)	m	kg	7.2			
		lb _m	16			
Ambient temperature		°C	0 to +40			
		°F	+32 to +104			
Lubrication			Lubricated for life			
Insulating material class			F			
Protection class			IP 65			
Paint			Blue metallic 250 and natural cast aluminium			
Metal bellows coupling (recommended product type – validate sizing with cymex®)			BCT-00060AAX-050.000			
Bore diameter of coupling on the application side		mm	X = 014.000 - 035.000			
Mass moment of inertia (relates to the drive)	J_1	kgcm ²	2.38	2.22	2.08	2
		10 ⁻³ in.lb.s ²	2.1	2	1.8	1.8

Please use our sizing software cymex® for a detailed sizing – www.wittenstein-cymex.com

^{a)} Refers to center of the output shaft or flange

^{b)} Please contact us to discuss application-specific service lifetimes.

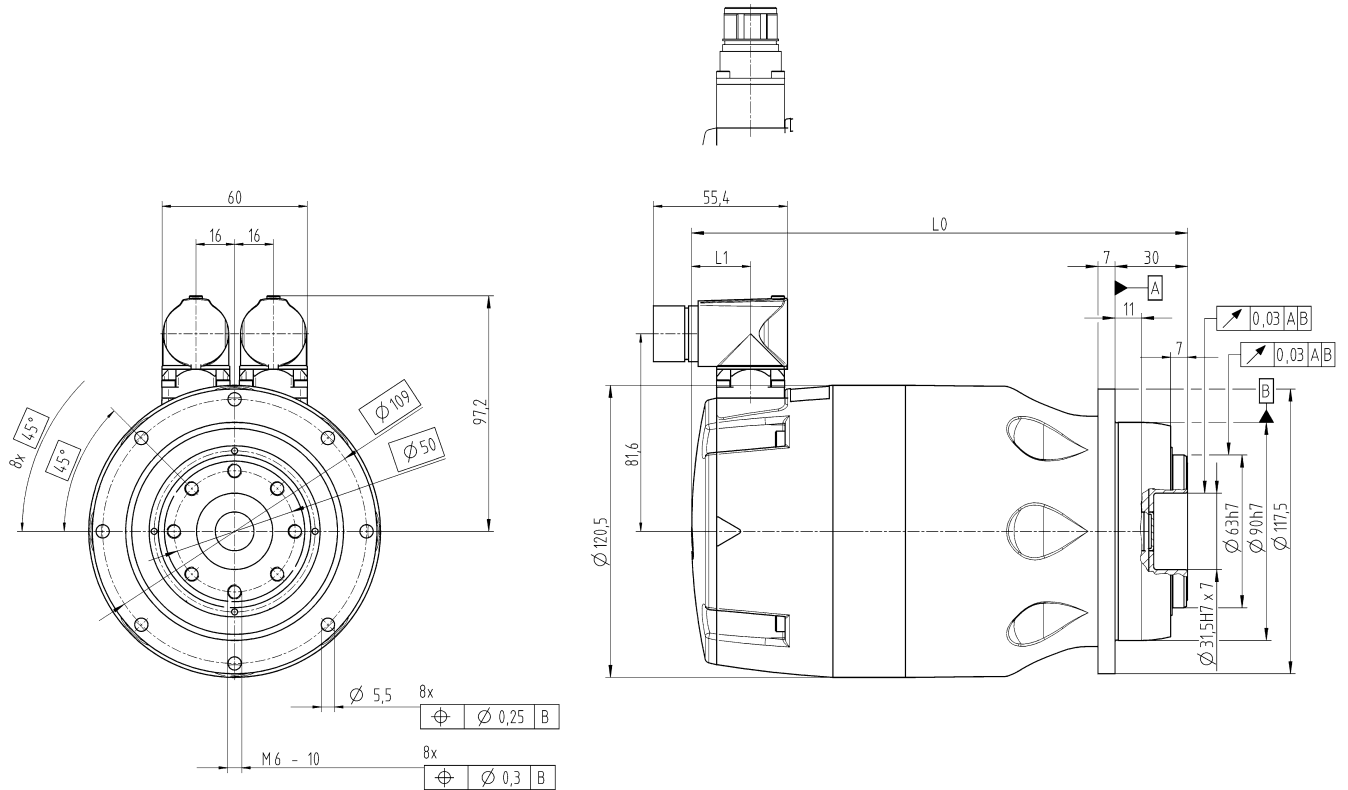

without brake

Ratio	Encoder	Length L0 in mm	Length L1 in mm
i = 4/5/7/10	Resolver	205	24
	HIPERFACE®	226	45
	EnDat	230	49

with brake

Ratio	Encoder	Length L0 in mm	Length L1 in mm
i = 4/5/7/10	Resolver	224	24
	HIPERFACE®	245	45
	EnDat	249	49

TPM+ POWER 010 2-stage

			2-stage								
Ratio	i		16	20	25	28	35	40	50	70	100
Operating voltage	U_D	VDC	560								
Max. acceleration torque (max. 1000 cycles per hour)	T_{2B}	Nm	130	130	130	130	130	130	130	130	100
		in.lb	1151	1151	1151	1151	1151	1151	1151	1151	885
Static output torque	T_{20}	Nm	66	84	90	90	90	48	62	86	60
		in.lb	584	743	797	797	797	425	549	761	531
Brake holding torque (at 120 °C)	T_{2Br}	Nm	72	90	112	126	158	180	225	250	180
		in.lb	637	797	991	1115	1398	1593	1991	2213	1593
Max. speed at output	n_{2max}	rpm	375	300	240	214	171	150	120	86	60
Speed limit for T_{2B}	n_{2B}	rpm	280	240	200	185	158	100	88	70	55
Max. motor acceleration torque	T_{1max}	Nm	12.1	12.1	12.1	12.1	12.1	4.4	4.4	4.4	4.4
		in.lb	107	107	107	107	107	39	39	39	39
Max. motor acceleration current	I_{MaxDyn}	A_{eff}	17	17	17	17	17	6	6	6	6
Static motor current	I_0	A_{eff}	5.4	5.4	5.4	5.4	5.4	1.9	1.9	1.9	1.9
Max. backlash	j_t	arcmin	Standard ≤ 3 Reduced ≤ 1								
Torsional rigidity (Gearbox)	C_{i21}	Nm/arcmin	32	32	32	31	32	30	30	28	22
		in.lb/arcmin	283	283	283	274	283	266	266	248	195
Tilting rigidity	C_{2K}	Nm/arcmin	225								
		in.lb/arcmin	1991								
Max. axial force ^{a)}	F_{2AMax}	N	2150								
		lb _f	484								
Max. tilting moment	M_{2KMax}	Nm	270								
		in.lb	2390								
Service life ^{b)}	L_h	h	> 20000								
Weight (without brake)	m	kg	6 to 7.4								
		lb _m	13 to 16								
Ambient temperature		°C	0 to +40								
		°F	+32 to +104								
Lubrication			Lubricated for life								
Insulating material class			F								
Protection class			IP 65								
Paint			Blue metallic 250 and natural cast aluminium								
Metal bellows coupling (recommended product type – validate sizing with cymex®)			BCT-00060AAX-050.000								
Bore diameter of coupling on the application side		mm	X = 014.000 - 035.000								
Mass moment of inertia (relates to the drive)	J_1	kgcm ²	2.02	1.99	1.98	1.96	1.96	0.72	0.72	0.72	0.72
		10 ⁻³ in.lb.s ²	1.8	1.8	1.8	1.7	1.7	0.64	0.64	0.64	0.64

Please use our sizing software cymex® for a detailed sizing – www.wittenstein-cymex.com

^{a)} Refers to center of the output shaft or flange

^{b)} Please contact us to discuss application-specific service lifetimes.

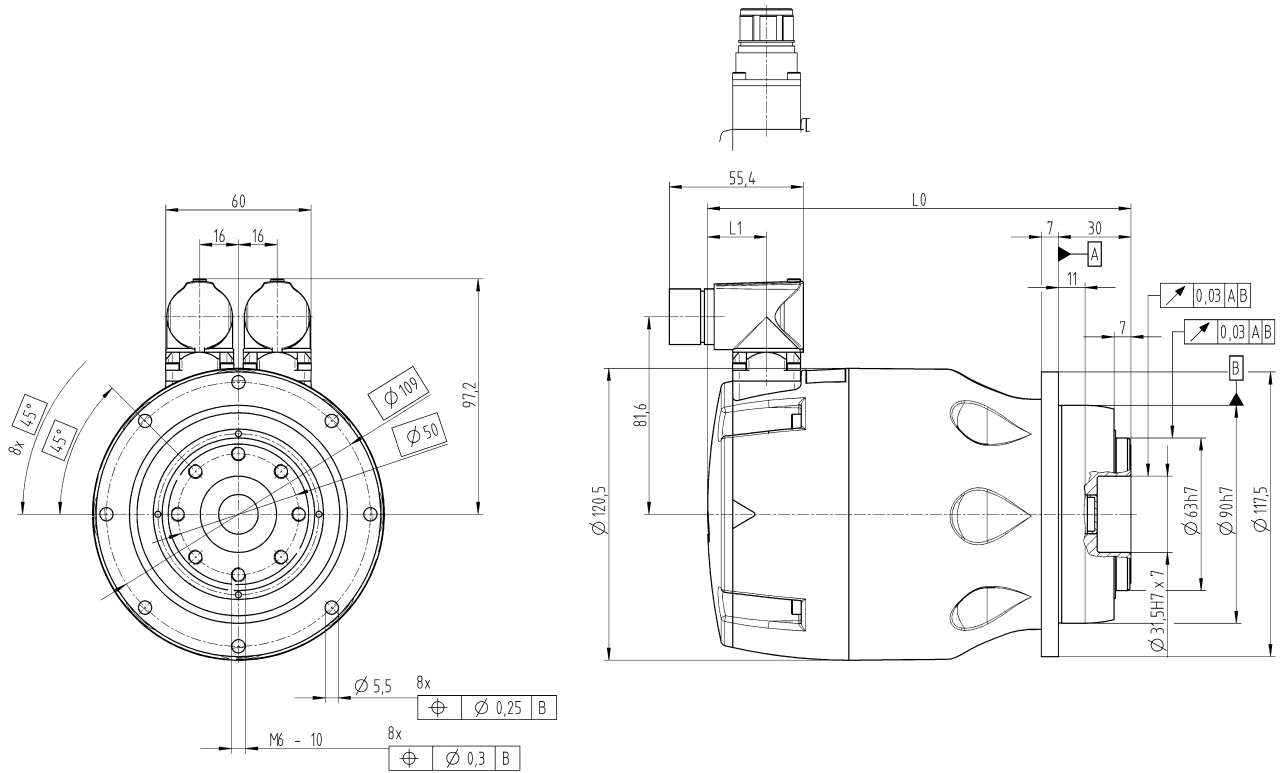

without brake

Ratio	Encoder	Length L0 in mm	Length L1 in mm
i = 16/20/25/28/35	Resolver	205	24
	HIPERFACE®	226	45
	EnDat	230	49
i = 40/50/70/100	Resolver	175	24
	HIPERFACE®	196	45
	EnDat	200	49

with brake

Ratio	Encoder	Length L0 in mm	Length L1 in mm
i = 16/20/25/28/35	Resolver	224	24
	HIPERFACE®	245	45
	EnDat	249	49
i = 40/50/70/100	Resolver	194	24
	HIPERFACE®	215	45
	EnDat	219	49

TPM+

TPM+ POWER 025 1-stage

			1-stage			
Ratio	i		4	5	7	10
Operating voltage	U_D	V DC	560			
Max. acceleration torque (max. 1000 cycles per hour)	T_{2B}	Nm	112	141	199	200
		in.lb	991	1248	1761	1770
Static output torque	T_{20}	Nm	43	55	78	113
		in.lb	381	487	690	1000
Brake holding torque (at 120 °C)	T_{2Br}	Nm	52	65	91	130
		in.lb	460	575	805	1151
Max. speed at output	n_{2max}	rpm	1500	1200	857	600
Speed limit for T_{2B}	n_{2B}	rpm	900	720	520	420
Max. motor acceleration torque	T_{1max}	Nm	28.9	28.9	28.9	28.9
		in.lb	256	256	256	256
Max. motor acceleration current	I_{MaxDyn}	A_{eff}	40	40	40	40
Static motor current	I_0	A_{eff}	13.7	13.7	13.7	13.7
Max. backlash	j_t	arcmin	Standard ≤ 3 Reduced ≤ 1			
Torsional rigidity (Gearbox)	C_{i21}	Nm/arcmin	80	86	76	62
		in.lb/arcmin	708	761	673	549
Tilting rigidity	C_{2K}	Nm/arcmin	550			
		in.lb/arcmin	4868			
Max. axial force ^{a)}	F_{2AMax}	N	4150			
		lb _f	934			
Max. tilting moment	M_{2KMax}	Nm	440			
		in.lb	3894			
Service life ^{b)}	L_h	h	> 20000			
Weight (without brake)	m	kg	14			
		lb _m	31			
Ambient temperature		°C	0 to +40			
		°F	+32 to +104			
Lubrication			Lubricated for life			
Insulating material class			F			
Protection class			IP 65			
Paint			Blue metallic 250 and natural cast aluminium			
Metal bellows coupling (recommended product type – validate sizing with cymex®)			BCT-00150AAX-063.000			
Bore diameter of coupling on the application side		mm	X = 019.000 - 042.000			
Mass moment of inertia (relates to the drive)	J_1	kgcm ²	9.98	9.5	9.07	8.84
		10 ⁻³ in.lb.s ²	8.8	8.4	8	7.8

Please use our sizing software cymex® for a detailed sizing – www.wittenstein-cymex.com

^{a)} Refers to center of the output shaft or flange

^{b)} Please contact us to discuss application-specific service lifetimes.

TPM+ POWER 025 2-stage

			2-stage								
Ratio	i		16	20	25	28	35	40	50	70	100
Operating voltage	U_D	V DC	560								
Max. acceleration torque (max. 1000 cycles per hour)	T_{2B}	Nm	350	350	380	350	380	305	380	330	265
		in.lb	3098	3098	3363	3098	3363	2699	3363	2921	2345
Static output torque	T_{20}	Nm	181	210	200	210	220	113	142	200	120
		in.lb	1602	1859	1770	1859	1947	1000	1257	1770	1062
Brake holding torque (at 120 °C)	T_{2Br}	Nm	208	260	325	364	455	520	625	625	600
		in.lb	1841	2301	2877	3222	4027	4602	5532	5532	5310
Max. speed at output	n_{2max}	rpm	375	300	240	214	171	150	120	86	60
Speed limit for T_{2B}	n_{2B}	rpm	260	220	185	170	140	90	70	65	50
Max. motor acceleration torque	T_{1max}	Nm	28.9	28.9	28.9	28.9	28.9	7.8	7.8	7.8	7.8
		in.lb	256	256	256	256	256	69	69	69	69
Max. motor acceleration current	I_{MaxDyn}	A_{eff}	40	40	40	40	40	12	12	12	12
Static motor current	I_0	A_{eff}	13.7	13.7	13.7	13.7	13.7	4	4	4	4
Max. backlash	j_t	arcmin	Standard ≤ 3 Reduced ≤ 1								
Torsional rigidity (Gearbox)	C_{i21}	Nm/arcmin	81	81	83	80	82	76	80	71	60
		in.lb/arcmin	717	717	735	708	726	673	708	628	531
Tilting rigidity	C_{2K}	Nm/arcmin	550								
		in.lb/arcmin	4868								
Max. axial force ^{a)}	F_{2AMax}	N	4150								
		lb _f	934								
Max. tilting moment	M_{2KMax}	Nm	440								
		in.lb	3894								
Service life ^{b)}	L_h	h	> 20000								
Weight (without brake)	m	kg	10.3 to 14.5								
		lb _m	23 to 32								
Ambient temperature		°C	0 to +40								
		°F	+32 to +104								
Lubrication			Lubricated for life								
Insulating material class			F								
Protection class			IP 65								
Paint			Blue metallic 250 and natural cast aluminium								
Metal bellows coupling (recommended product type – validate sizing with cymex®)			BCT-00150AAX-063.000								
Bore diameter of coupling on the application side		mm	X = 019.000 - 042.000								
Mass moment of inertia (relates to the drive)	J_1	kgcm ²	8.94	8.83	8.81	8.72	8.71	2.48	2.48	2.48	2.47
		10 ⁻³ in.lb.s ²	7.9	7.8	7.8	7.7	7.7	2.2	2.2	2.2	2.2

Please use our sizing software cymex® for a detailed sizing – www.wittenstein-cymex.com

^{a)} Refers to center of the output shaft or flange

^{b)} Please contact us to discuss application-specific service lifetimes.

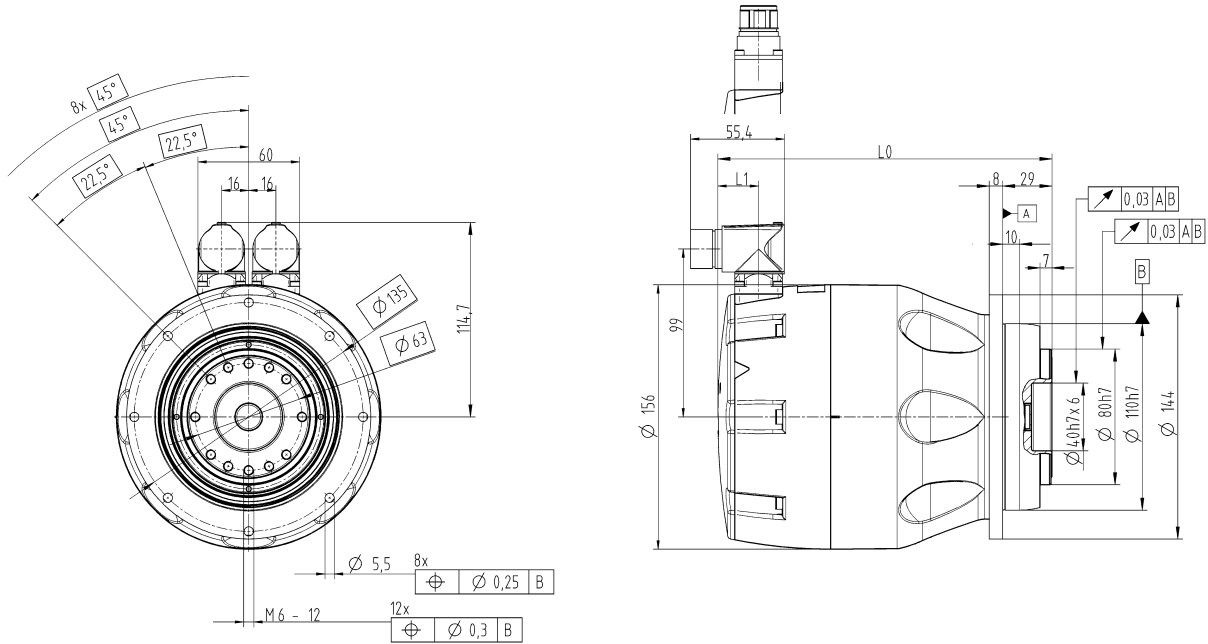

without brake

Ratio	Encoder	Length L0 in mm	Length L1 in mm
i = 16/20/25/28/35	Resolver	242	24
	HIPERFACE®	263	45
	EnDat	267	49
i = 40/50/70/100	Resolver	197	24
	HIPERFACE®	218	45
	EnDat	222	49

with brake

Ratio	Encoder	Length L0 in mm	Length L1 in mm
i = 16/20/25/28/35	Resolver	266	24
	HIPERFACE®	287	45
	EnDat	291	49
i = 40/50/70/100	Resolver	221	24
	HIPERFACE®	242	45
	EnDat	246	49

TPM+ POWER 050 1-stage

			1-stage			
Ratio	i		4	5	7	10
Operating voltage	U_D	V DC	560			
Max. acceleration torque (max. 1000 cycles per hour)	T_{2B}	Nm	221	278	340	350
		in.lb	1956	2461	3009	3098
Static output torque	T_{20}	Nm	72	91	130	188
		in.lb	637	805	1151	1664
Brake holding torque (at 120 °C)	T_{2Br}	Nm	92	115	161	230
		in.lb	814	1018	1425	2036
Max. speed at output	n_{2max}	rpm	1250	1000	714	500
Speed limit for T_{2B}	n_{2B}	rpm	780	620	450	370
Max. motor acceleration torque	T_{1max}	Nm	56.6	56.6	56.6	56.6
		in.lb	501	501	501	501
Max. motor acceleration current	I_{MaxDyn}	A_{eff}	63.5	63.5	63.5	63.5
Static motor current	I_0	A_{eff}	19	19	19	19
Max. backlash	j_t	arcmin	Standard ≤ 3 Reduced ≤ 1			
Torsional rigidity (Gearbox)	C_{i21}	Nm/arcmin	190	187	159	123
		in.lb/arcmin	1682	1655	1407	1089
Tilting rigidity	C_{2K}	Nm/arcmin	560			
		in.lb/arcmin	4956			
Max. axial force ^{a)}	F_{2AMax}	N	6130			
		lb _f	1379			
Max. tilting moment	M_{2KMax}	Nm	1335			
		in.lb	11816			
Service life ^{b)}	L_h	h	> 20000			
Weight (without brake)	m	kg	23.6			
		lb _m	52			
Ambient temperature		°C	0 to +40			
		°F	+32 to +104			
Lubrication			Lubricated for life			
Insulating material class			F			
Protection class			IP 65			
Paint			Blue metallic 250 and natural cast aluminium			
Metal bellows coupling (recommended product type – validate sizing with cymex®)			BCT-00300AAX-080.000			
Bore diameter of coupling on the application side		mm	X = 024.000 - 060.000			
Mass moment of inertia (relates to the drive)	J_1	kgcm ²	26.4	24.8	23.3	22.5
		10 ⁻³ in.lb.s ²	23	22	21	20

Please use our sizing software cymex® for a detailed sizing – www.wittenstein-cymex.com

^{a)} Refers to center of the output shaft or flange

^{b)} Please contact us to discuss application-specific service lifetimes.

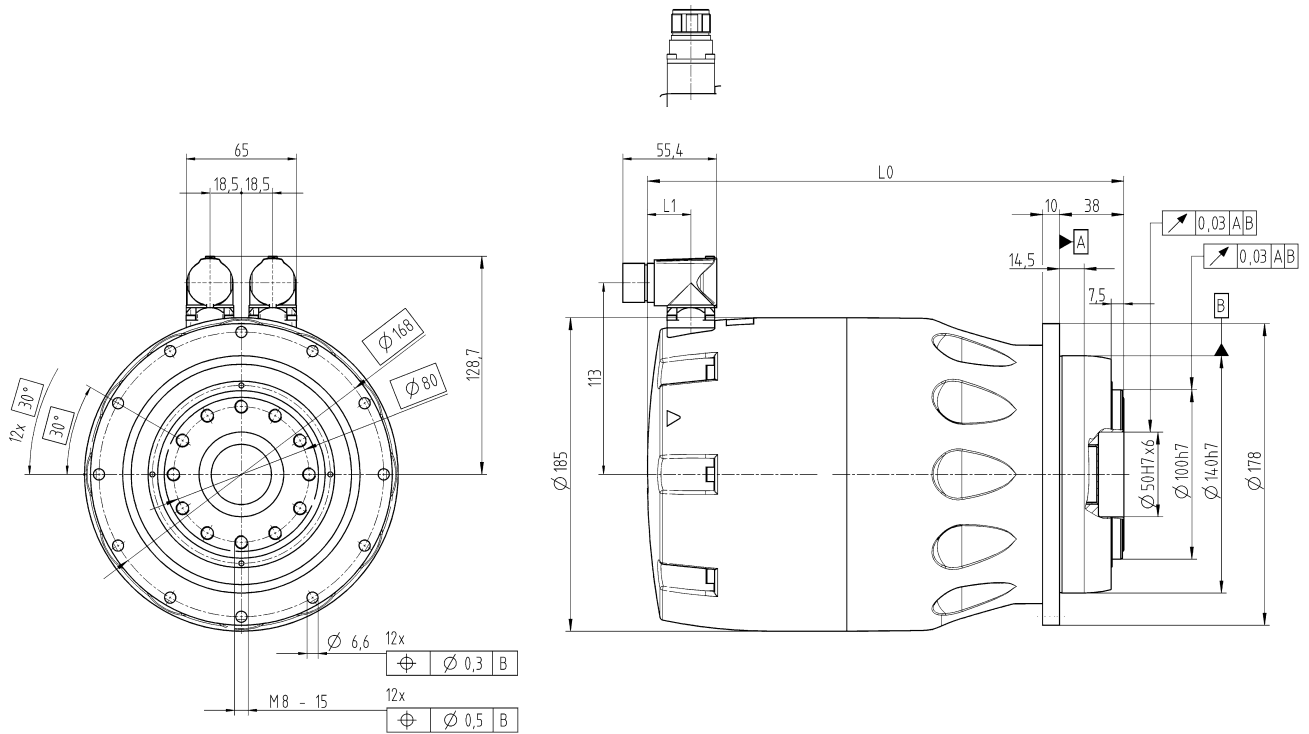

without brake

Ratio	Encoder	Length L0 in mm	Length L1 in mm
i = 4/5/7/10	Resolver	281	26
	HIPERFACE®	306	50
	EnDat	306	50

with brake

Ratio	Encoder	Length L0 in mm	Length L1 in mm
i = 4/5/7/10	Resolver	321	26
	HIPERFACE®	346	50
	EnDat	346	50

TPM+ POWER 050 2-stage

			2-stage								
Ratio	i		16	20	25	28	35	40	50	70	100
Operating voltage	U_D	VDC	560								
Max. acceleration torque (max. 1000 cycles per hour)	T_{2B}	Nm	750	750	750	750	750	607	750	700	540
		in.lb	6638	6638	6638	6638	6638	5372	6638	6196	4779
Static output torque	T_{20}	Nm	293	371	400	400	400	199	250	354	240
		in.lb	2593	3284	3540	3540	3540	1761	2213	3133	2124
Brake holding torque (at 120 °C)	T_{2Br}	Nm	368	460	575	644	805	920	1150	1250	1100
		in.lb	3257	4071	5089	5700	7125	8143	10178	11064	9736
Max. speed at output	n_{2max}	rpm	312	250	200	179	143	125	100	71	50
Speed limit for T_{2B}	n_{2B}	rpm	210	180	155	145	125	90	80	65	50
Max. motor acceleration torque	T_{1max}	Nm	56.6	56.6	56.6	56.6	56.6	15.6	15.6	15.6	15.6
		in.lb	501	501	501	501	501	138	138	138	138
Max. motor acceleration current	I_{MaxDyn}	A_{eff}	63.5	63.5	63.5	63.5	63.5	33	33	33	33
Static motor current	I_0	A_{eff}	19	19	19	19	19	7.5	7.5	7.5	7.5
Max. backlash	j_t	arcmin	Standard ≤ 3 Reduced ≤ 1								
Torsional rigidity (Gearbox)	C_{i21}	Nm/arcmin	180	185	180	180	175	175	175	145	115
		in.lb/arcmin	1593	1637	1593	1593	1549	1549	1549	1283	1018
Tilting rigidity	C_{2K}	Nm/arcmin	560								
		in.lb/arcmin	4956								
Max. axial force ^{a)}	F_{2AMax}	N	6130								
		lb _f	1379								
Max. tilting moment	M_{2KMax}	Nm	1335								
		in.lb	11816								
Service life ^{b)}	L_h	h	> 20000								
Weight (without brake)	m	kg	19.4 to 25.1								
		lb _m	43 to 55								
Ambient temperature		°C	0 to +40								
		°F	+32 to +104								
Lubrication			Lubricated for life								
Insulating material class			F								
Protection class			IP 65								
Paint			Blue metallic 250 and natural cast aluminium								
Metal bellows coupling (recommended product type – validate sizing with cymex®)			BCT-00300AAX-080.000								
Bore diameter of coupling on the application side		mm	X = 024.000 - 060.000								
Mass moment of inertia (relates to the drive)	J_1	kgcm ²	23.1	22.6	22.6	22.2	22.2	6.3	6.3	6.3	6.3
		10 ⁻³ in.lb.s ²	20	20	20	20	20	5.6	5.6	5.6	5.6

Please use our sizing software cymex® for a detailed sizing – www.wittenstein-cymex.com

^{a)} Refers to center of the output shaft or flange

^{b)} Please contact us to discuss application-specific service lifetimes.



TPM⁺ options

Electrical connection

Straight or angled version.

Encoder

In addition to the standard version with resolver, optional encoder systems with the protocols EnDat 2.1 and HIPERFACE® are available.

Pin assignment

For a number of servo controllers, we offer special pin assignments for power and signal.

Operating voltage

Depending on the application and servo regulator, windings for 48, 320 and 560 V DC are available.

Temperature sensor

Choose from PTC for temperature switch functionality or PT1000 for a linear reading of operating temperature.

Lubrication

Select from the standard lubrication with oil or grease as well as food-grade grease and oil.

Holding brake

A suitable permanent-magnet holding brake adapted to the motor power is available.

Available output types

Flange, System output

Backlash

To improve precision, the gearbox backlash can be reduced.

Increased corrosion protection

For applications with requirements in terms of resistance to water and cleaning agents a version with greater corrosion protection and protection class IP 66 is available.



TPM⁺ options

Lubrication

Depending on the application, the requirements regarding the lubricant in the gearbox change.

The following lubricants are available for our servo actuators:

- Oil (Standard)
- Grease
(Reduction of output torque by up to 20 %)
- Food-grade oil
(Reduction of output torque by up to 20 %)
- Food-grade grease
(Reduction of output torque by up to 40 %)

Operating voltage

The TPM⁺ servo actuators are available for operating voltages of 48 V (only TPM⁺ DYNAMIC 004 and 010, TPM⁺ POWER 004), 320 V and 560 V.

Temperature sensor

Different sensors are available to protect the motor coil from overheating.

- PTC resistor, type STM 160 according to DIN 44081/82
- PT1000

Encoder

A large selection of encoder systems is available for positioning and speed measurement:

Resolver

- 2-pin, one sine/cosine cycle per rotation

HIPERFACE[®] absolute encoder

- Singleturn, resolution 4096 positions per revolution, 128 sine/cosine
- Multiturn, resolution 4096 positions per revolution, 128 sine/cosine, 4096 revolutions

EnDat 2.1, absolute encoder

- Singleturn, resolution 8192 positions per revolution, 512 sine/cosine
- Multiturn, resolution 8192 positions per revolution, 512 sine/cosine, 4096 revolutions

HIPERFACE DSL[®], EnDat 2.2 or DRIVE-CLiQ upon request

Holding brake

A compact permanent magnet brake is fitted to secure the motor shaft when the actuator is disconnected from the power. Characteristics include holding without torsional backlash, no residual torque when the brake is released and unlimited power-on time at zero speed.

Size DYNAMIC		004 and 010	025	050 and 110
Holding torque at 120 °C	Nm	1.1	4.5	13
Supply voltage	V DC	24 + 6% / -10%		
Current	A	0.42	0.42	0.71

Size POWER		004	010	025	050
Holding torque at 120 °C	Nm	1.1	4.5	13	23
Supply voltage	V DC	24 + 6% / -10%			
Current	A	0.42	0.42	0.51	1

Size HIGH TORQUE		10		25		50	
Ratios		22 – 110	154 – 220	22 – 55	66 – 220	22 – 55	66 – 220
Holding torque at 120 °C	Nm	4.5	1.8	13	4.5	23	13
Supply voltage	V DC	24 + 6% / -10%					
Current	A	0.42	0.42	0.71	0.42	1	0.71

In the case of high ratios, a brake with a reduced holding torque is partly used to prevent damage to the gearbox. The exact holding torques at the output can be found in the relevant data tables for the actuators. In the case of transmission ratios in which the holding torque at the output is above T_{2B} , the brake can be used max. 1000 times for emergency stopping on the rotating motor.

TPM+ options

Electrical connection

The conventional connection via two integral sockets for power and signal is available, as well as a version for a single-cable connection, which is available upon request.

Integral sockets used:

Two-cable connection	Power	Integral power socket M23 Bayonet coupling, 6/9-pin
	Signal	Integral signal socket M23 Bayonet coupling, 9/12/17-pin

Pin assignment

In addition to two standard WITTENSTEIN pin assignments, a number of compatible connections are available for various servo controller suppliers.

Pin assignment 1	WITTENSTEIN alpha-Standard, temperature sensor in signal cable Resolver, HIPERFACE®, EnDat 2.1
Pin assignment 4	WITTENSTEIN alpha-Standard, temperature sensor in power cable Resolver, HIPERFACE®, EnDat 2.1
Pin assignment 5	Rockwell compatible HIPERFACE®

Pin assignment 6	B&R compatible Resolver, EnDat 2.1
Pin assignment 8	Schneider compatible HIPERFACE®
Pin assignment 9	Beckhoff compatible Resolver, EnDat 2.1

Increased corrosion protection

All actuators of the "TPM+" product range (except Size 004 DYNAMIC) are optionally available with increased corrosion protection.

Versions

- 1 Chemically nickel-plated gearbox housing.
- 2 Stainless steel output flange and shaft nut.
- 3 Small external stainless steel screws.
- 4 Additional U-seals on the external screws.
- 5 Base (chemically nickel plated) for integral socket with laser-marking of identification plate.
- 6 All versions are generally equipped with straight integral socket only.
- 7 The TPM+ is completely painted with a highly resistant, two-component epoxy resin based material.
Colors: - Ultramarine blue silk matte (RAL 5002)
- Papyrus white silk matte (RAL 9018)

Fields of application

- Outdoor use in gates, conveyors etc.
- Packaging machines outside of the food sector.
- Textile machines.
- Pharmaceutical plants outside of the medical sector.

Resistance

- to water and moisture.
 - restricted due to cleaning agents, especially under extended exposure period.
- Successful tests with Oxofam VF5L (Johnson Diversey) and Ultraclean VK3 (Johnson Diversey).
- Further cleaning agents can be qualified on request.

Protection class

Against spray water: IP 66

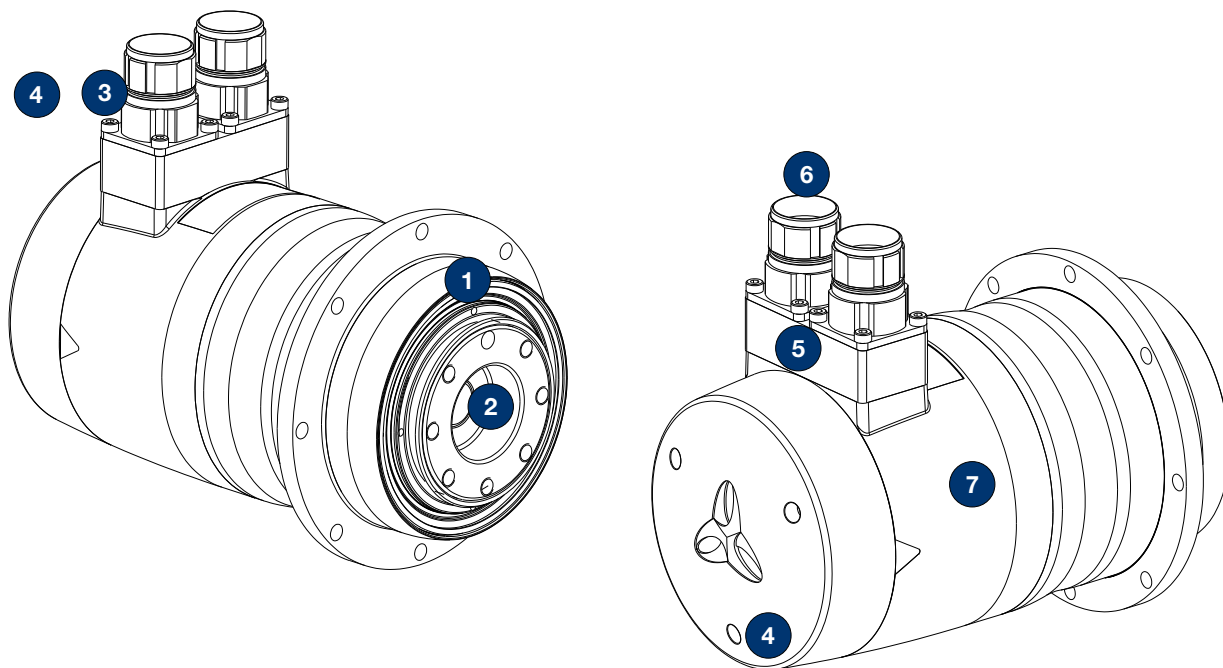

TPM+ Ordering code

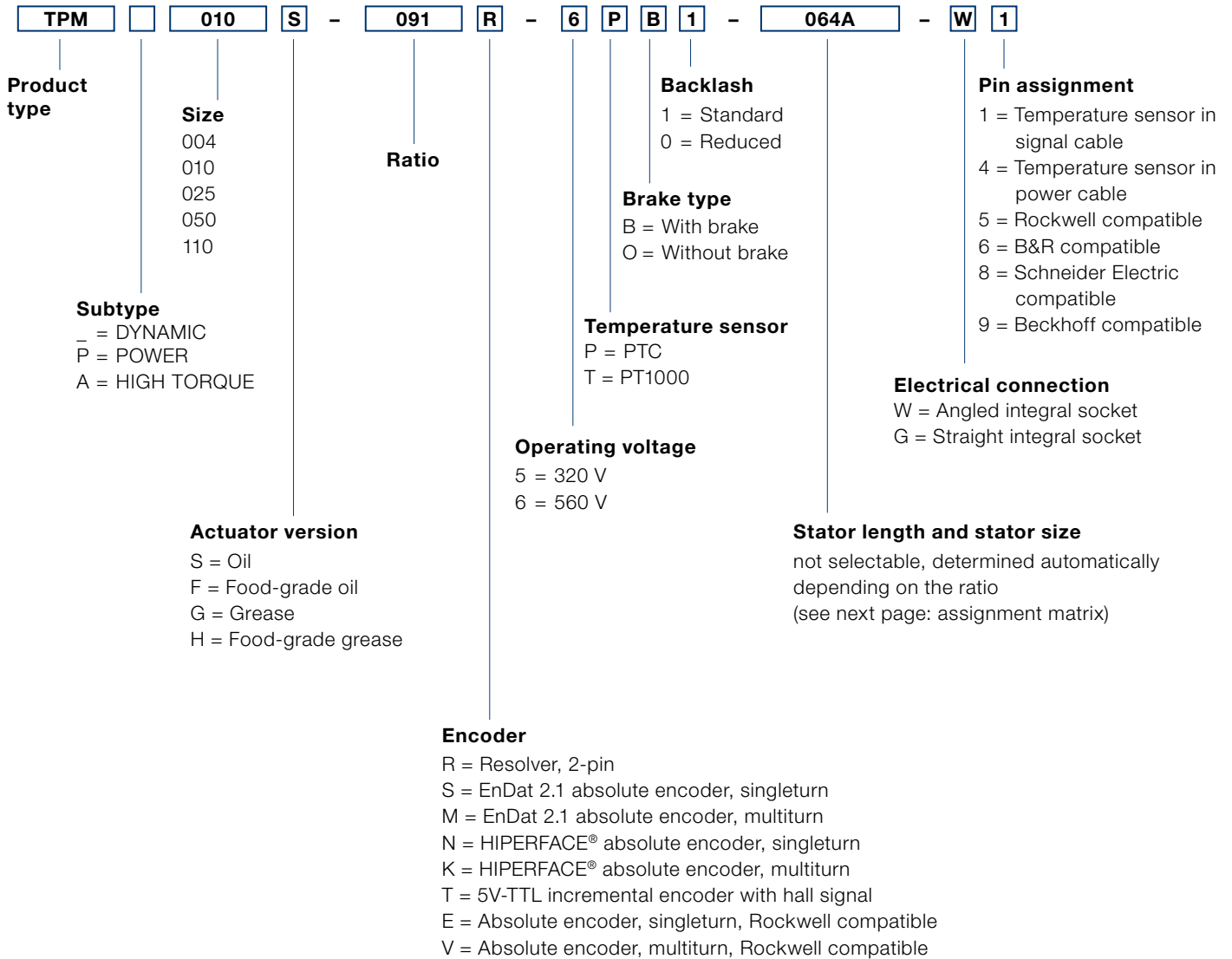

Motor / gearbox assignment matrix

Ratio	Size 004		Size 010			Size 025			Size 050			Size 110
	DYNAMIC	POWER	DYNAMIC	POWER	HIGH TORQUE	DYNAMIC	POWER	HIGH TORQUE	DYNAMIC	POWER	HIGH TORQUE	DYNAMIC
4	x	64B	x	94C	x	x	130D	x	x	155D	x	x
5	x	64B	x	94C	x	x	130D	x	x	155D	x	x
7	x	64B	x	94C	x	x	130D	x	x	155D	x	x
10	x	64B	x	94C	x	x	130D	x	x	155D	x	x
16	53B	64B	64B	94C	x	94C	130D	x	130D	155D	x	130E
20	x	64B	x	94C	x	x	130D	x	x	155D	x	x
21	53B	x	64B	x	x	94C	x	x	130D	x	x	130E
22	x	x	x	x	94C	x	x	130D	x	x	155D	x
25	x	64B	x	94C	x	x	130D	x	x	155D	x	x
27,5	x	x	x	x	94C	x	x	130D	x	x	155D	x
28	x	64B	x	94C	x	x	130D	x	x	155D	x	x
31	53B	x	64B	x	x	94C	x	x	130D	x	x	130E
35	x	64B	x	94C	x	x	130D	x	x	155D	x	x
38,5	x	x	x	x	94C	x	x	130D	x	x	155D	x
40	x	64A	x	94A	x	x	130A	x	x	155A	x	x
50	x	64A	x	94A	x	x	130A	x	x	155A	x	x
55	x	x	x	x	94C	x	x	130D	x	x	155D	x
61	53A	x	64A	x	x	94A	x	x	130A	x	x	130D
64	53A	x	64A	x	x	94A	x	x	130A	x	x	130D
66	x	x	x	x	x	x	x	94C	x	x	130D	x
70	x	64A	x	94A	x	x	130A	x	x	155A	x	x
88	x	x	x	x	94C	x	x	94C	x	x	130D	x
91	53A	x	64A	x	x	94A	x	x	130A	x	x	130D
100	x	64A	x	94A	x	x	130A	x	x	155A	x	x
110	x	x	x	x	94C	x	x	94C	x	x	130D	x
154	x	x	x	x	94A	x	x	94C	x	x	130D	x
220	x	x	x	x	94A	x	x	94C	x	x	130D	x

x = no standard combination